

Seetru Limited

Seetru are Bristol-based manufacturers of safety relief and other special purpose ancillary valves for a wide range of compressed air, industrial gas, refrigerants, powder, steam, liquid and liquefied gas applications. Seetru change-over valves offer increased plant and process efficiency.

Seetru liquid level gauges are primarily of two types, sight gauges and magnetic float bypass gauges. Many of the gauges are direct reading though most have optional electronic remote reading systems and computer interfaces.



Seetru Liquid Level Gauges

GENERAL INDUSTRY | CHEMICAL | REFRIGERANTS | SHIPBUILDING & OFFSHORE



LIQUID LEVEL GAUGES



Seetru Limited
That's The Level!

Edition: 12th July 2022



Seetru Limited was founded in 1949 with the aim of producing the finest liquid level gauges so customers could “see the true” level even under the most severe conditions. This philosophy of making the finest through innovation continued with the introduction of the Seetru range of pressure relief devices, circa 1950 the Seetru Tutchtite-sealing system revolutionized the safety valve market with valves that do not leak even after repeated popping even at high pressures.

Today, Seetru have an extensive range of Pressure Relief Valves and Liquid Level Gauges which carry a wide range of international approvals and are supplied worldwide.

Our Products

Seetru liquid level gauges are primarily of two types, sight gauges and magnetic float by-pass gauges. Many of the gauges are direct reading though most have optional electronic remote reading systems and computer interfaces. The range includes the Quickmount, Seemag and CPI gauges for industrial and chemical applications, and the Seeflex and Seemag for marine applications. The Company’s substantial design and development department, which includes TÜV approved testing facilities, enable us to provide extensive bespoke design, advisory and manufacturing services to develop or adapt individual products for new applications.

Seetru are Bristol-based manufacturers of safety relief valves and other special purpose ancillary valves for a wide range of compressed air, industrial gas, refrigerants, powder, steam, liquid and liquefied gas applications. These valves meet important international standards which include: ISO-4126-1 & -7 and ASME BPVC VIII.1 & XIII design codes as well as type test approvals from TÜV and the National Board. These products comply with the requirements of the European Pressure Equipment Directive (PED) and are available with both the CE mark as well as the UV stamp, and have wide international approvals such as the EAC (TR CU) customs union certification and declaration and the Canadian CRN. Seetru products are fully compliant with the requirements of the UK Pressure Equipment (Safety) Regulations and come with the UKCA mark.



Seetru also have a wide range of special purpose valves. The range includes Change-Over Valves (designed for switching parallel safety valves without interrupting operation), Minimum Pressure Check Valves (typically suitable for application on compressors), Air-Start Valves (designed to handle a two-stage operation for air starting of large diesel engines). We also manufacture a range of Air Receiver & In-line Check Valves.

Table of contents



TYPE	PRODUCT / DESIGN	INLET CONNECTIONS	PRESSURES	APPLICATION / INDUSTRY	PAGE
G20 Admiralty	Tubular glass gauge	Brass or Stainless steel	Weld bosses	SHIPBUILDING & OFFSHORE	4-6
G21 Tubular Marine	Tubular glass gauge	Brass or Stainless steel	Weld bosses, threaded or flanged	SHIPBUILDING & OFFSHORE	7-8
G22 Quickmount	Tubular glass gauge	Brass, Stainless steel or Polypropylene	Threaded, flanged or weld bosses	GENERAL INDUSTRY CHEMICAL SHIPBUILDING & OFFSHORE	9-11
G23 CPI Tubular	Tubular glass gauge	Stainless Steel	Flanged	GENERAL INDUSTRY CHEMICAL	12-13
G27 Mini Gauge	Tubular glass gauge	Brass or Stainless steel	Threaded	GENERAL INDUSTRY CHEMICAL	14
G31 Seeflex	Flat glass gauge	Brass or Stainless steel	Weld bosses, threaded or flanged	SHIPBUILDING & OFFSHORE	15-17
G32 Quickflex	Flat glass gauge	Brass or Stainless steel	Threaded, flanged or weld bosses	GENERAL INDUSTRY CHEMICAL SHIPBUILDING & OFFSHORE	18-19
G33 Reflex Refrigeration	Flat glass Reflex gauge	Stainless steel or Mild steel	Threaded	REFRIGERANTS	20-21
G34B Reflex Ball Valves	Flat glass Reflex gauge	Stainless steel	Threaded or flanged	GENERAL INDUSTRY REFRIGERANTS SHIPBUILDING & OFFSHORE	22-24
G34 CPI Reflex	Flat glass Reflex gauge	Stainless steel	Flanged	GENERAL INDUSTRY CHEMICAL	25-26
G35 Seemag	Magnetic by-pass gauge	Stainless steel	Threaded, flanged or stub pipe for welding	GENERAL INDUSTRY CHEMICAL SHIPBUILDING & OFFSHORE REFRIGERANTS	27-30
SF / SG	Window Sight Glass	Zinc plated mild steel or Stainless steel	Threaded	GENERAL INDUSTRY CHEMICAL	31

G20 Admiralty Gauge

The Seetru Admiralty liquid level gauge is a direct reading, tubular design for marine & shipbuilding use. This gauge was designed and developed to meet arduous UK Ministry of Defence requirements, such as for tank deflection and underwater shock loads.

Example Applications

- Diesel
- Fuel oil
- Lubrication oil
- Water
- Coolant

Specifications

- Maximum working pressure for Glass Sight Tube: up to 22 bar & 15°C @ 400mm centres
- Maximum working pressure for Polycarbonate Sight Tube: up to 14 bar & 100°C.
- Maximum Operating Temperature: 150°C (depending on O-ring material)
- Maximum Centre Distance: (To suit requirements).
- Minimum Centre Distance: 150mm (For gauges longer than 1000mm, the column is split into sections using intermediate support). Each sections maximum length is 1000mm.



Materials of Construction

Component	Material
Valve Units and Flanges and Flanges	Brass
	Stainless Steel
Guard Tube	Aluminium
	Stainless Steel
	Brass
	Zinc Plated Mild Steel
Sight Tube	Borosilicate Heat Resisting Glass
	Polycarbonate Plastic
Weld Bosses	Mild Steel
	Stainless Steel

Seal Materials

Seal Material	Temperature Range
Nitrile (NBR)	Up to 120°C
Viton (FKM)	Up to 150°C
EPDM	Up to 150°C
Neoprene	Up to 140°C

Other seal materials available upon request.

Connection Options

Type	Size
Weld Boss	42mm



This unique gauge allows installation on misaligned tank connections as may, for example, be found on marine or other storage tanks of light walled construction which can deform or bulge. The tank connection valve fittings can accommodate misalignment vertically and along two mutually perpendicular axes horizontally through an adjustable fitting which enables correction of misalignment at the time of fitting or subsequently*. The valve fittings each form, in fact, a universal joint which gives the gauge its adaptability for difficult conditions of installation.

In the push-button version, the self closing valve is situated in the rear portion of the valve body which projects into the tank. This ensures leak-proof protection whatever damage occurs to the gauge parts on the outside of the tank.

This robust direct reading sight tube gauge has substantial passages and is suitable for use on any storage tanks or bunkers for up to medium heavy fuel oil.

Typical Misalignments accommodated

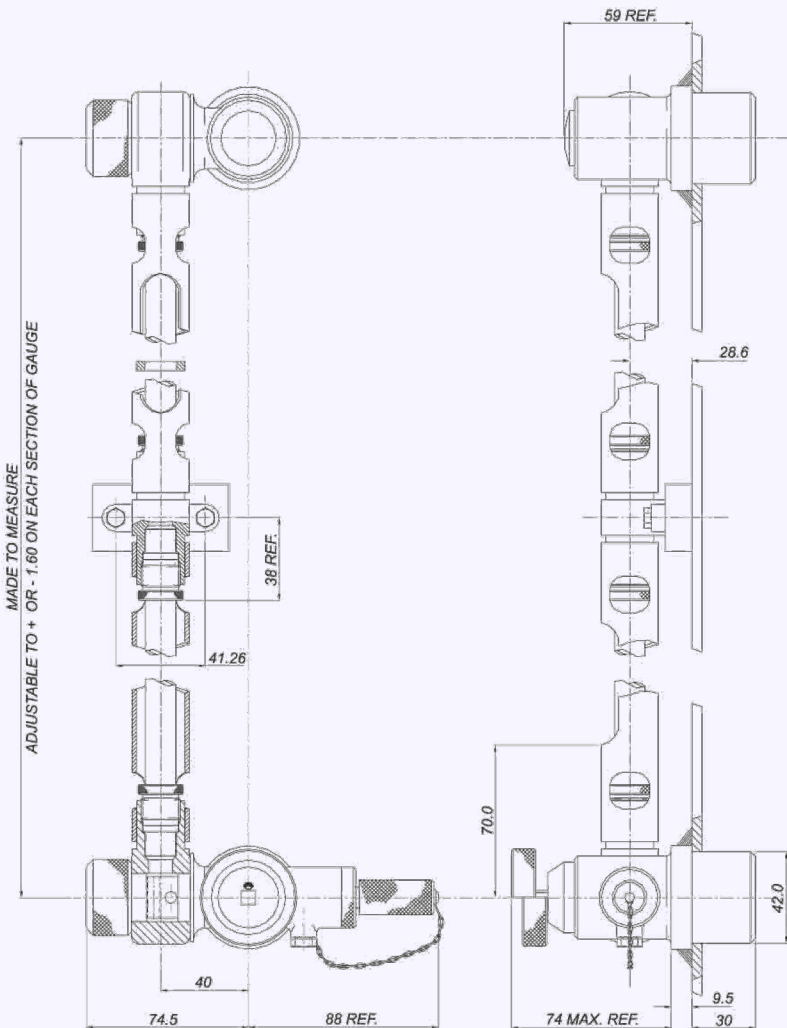
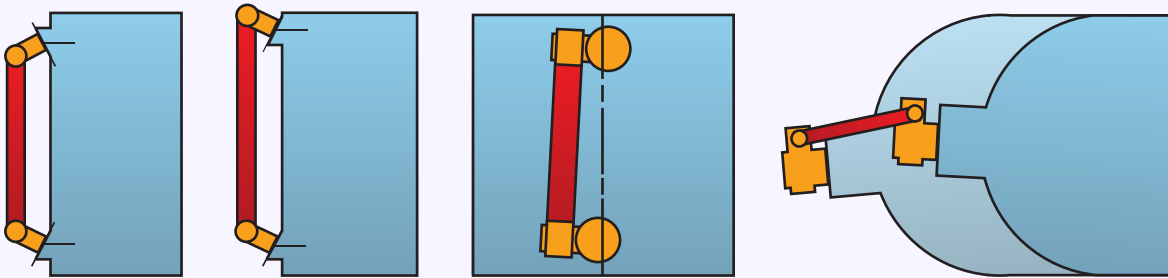

**Connection Options
(Top and Bottom)**

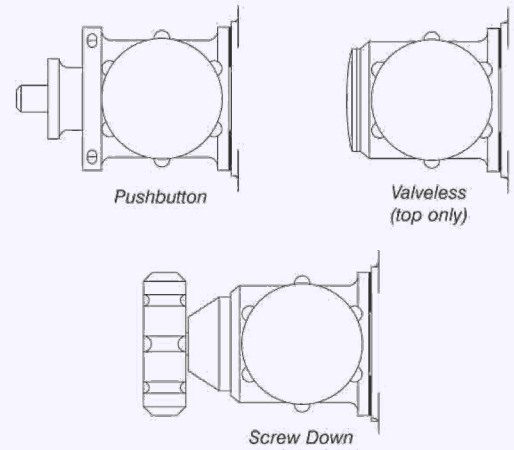

Contact Seetru for detailed advice on selection of gauge and configuration options to meet application requirements

**Optional Sampler Unit
(Available for bottom connection)**

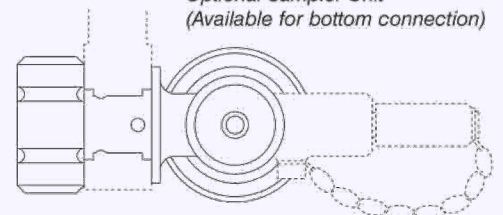

*The Admiralty gauges can only accommodate misalignments which occur subsequent to installation if no intermediate supports are fitted.



Push-button operation

Except when a reading is being taken, the gauge is permanently isolated from the contents of the tank. To take a reading the spring-loaded valve is opened by pressing a push-button; when released, the connection between the tank and gauge is automatically resealed.

Safe from external damage

Due to the design of the push-button isolation valve, no amount of damage to the gauge or external fittings on the tanks can break the liquid seals. In such an event the fluids cannot escape.

Graduation

Where a measure of the precise storage volume is required, an engraved scale plate can be provided marked with the capacity units.

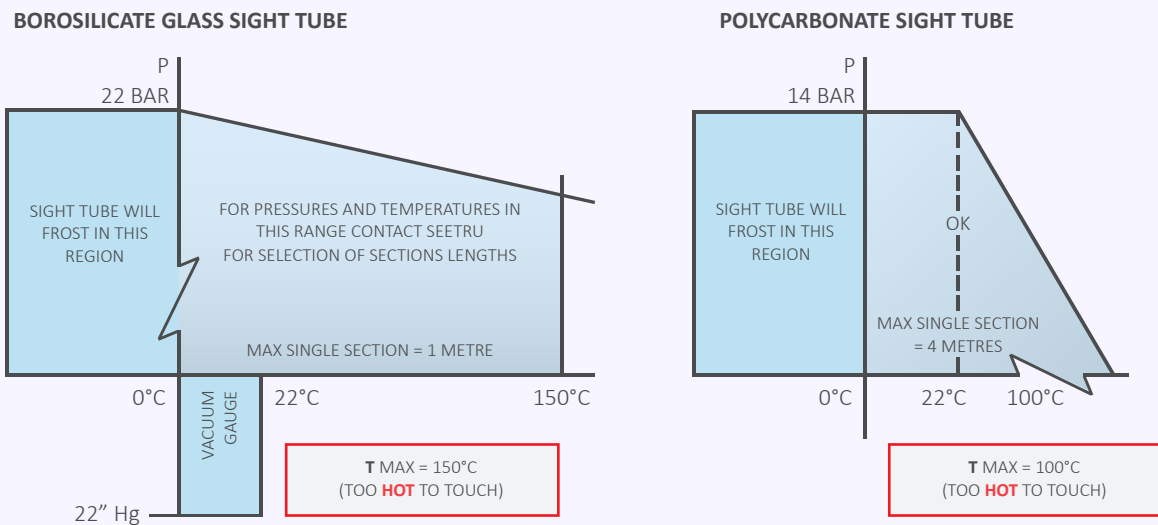

The above constraints are approved for water and other non-aggressive liquids only. For any liquid or for any constraint in excess of those given above, please consult Seetru.

Suggestions for fitting the Admiralty Gauge

The Seetru Admiralty gauge is supplied complete with tank bosses either for welding in position or for fitting by means of special sealing nuts without welding. Where the welded pattern bosses are used it is suggested that the gauge, complete with the bosses, be offered to the holes in the tank wall. The bosses can then be tack-welded to ensure correct positioning.

The gauge and mounting fittings can then be removed and the inside of the bosses protected with graphite grease to prevent oxidation during final welding. After welding the grease should be removed, and the fittings and gauge can then be re-assembled to the tank. Where the alternative non-weld pattern bosses are supplied, these can be positioned and tightened without removing the gauge. If, after fitting the tank bosses, a length adjustment of the gauge is still required, this can be achieved by slackening the sight tube gland nuts and re-tightening after the gauge collars have been correctly aligned.

The intermediate support brackets shown in the diagram are supplied typically for gauges longer than 1 m when fitted with Borosilicate glass sight tubes. The intermediate support brackets may not be necessary when Polycarbonate sight tubes are fitted (contact Seetru for further information).

When fitted with support brackets the gauge is supplied in sections, marked for easy assembly. In this way Seetru gauges are also safeguarded against damage in transit.

Type G21 Tubular Marine

The Seetru Marine gauge is designed for use within the marine and offshore industries. Due to its tubular design this gauge is suitable only for use with non-flammable liquids. For flammable liquid applications please see either G35 Seemag or G31 Seeflex.

This gauge is commonly used for the water storage and coolant tanks on board cargo ships, tugs and military vessels.

Example Applications

- Diesel (on land applications)
- Fuel oil (on land applications)
- Water
- Coolants

Specifications

- Maximum working pressure: up to 3.68 bar
- Maximum Operating Temperature: 150°C (depending on O-ring material and sight tube material)
- Maximum Centre Distance: (To suit requirements)
- Minimum Centre Distance – Closed Circuit Design: 150mm (For gauges longer than 1000mm, the column is split into sections using intermediate supports).
- Each section maximum length is 1000mm.

Approvals

- Conforms with EN BS ISO10088 Recreational Craft Directive

Materials of Construction

Component	Material
Valve Units	Brass
	Stainless Steel
Guard Tube	Aluminium
	Stainless Steel
	Brass
	Zinc Plated Mild Steel
Sight Tube	Borosilicate Heat Resisting Glass
	Polycarbonate Plastic
Weld Bosses / Flanges	Zinc Plated Mild Steel
	Stainless Steel

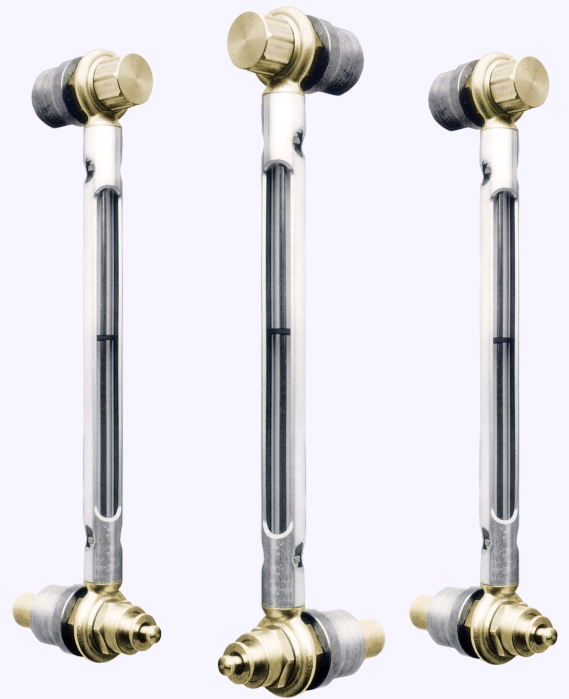

Seal Materials

Seal Material	Temperature Range
Nitrile (NBR)	Up to 120°C
Viton (FKM)	Up to 150°C
EPDM	Up to 150°C
Neoprene	Up to 140°C

Other seal materials available upon request.

Connection Options

Type	Size
Threaded Connections	1/2" BSP or NPT
	3/4" BSP or NPT
Flanged Connections	DIN Flanges
	ANSI Flanges
Weld Boss	42mm OD



Gauge always supplied with a push button self-closing isolation valve at the bottom connection.

Closed Circuit Design

(Connection at top and bottom)

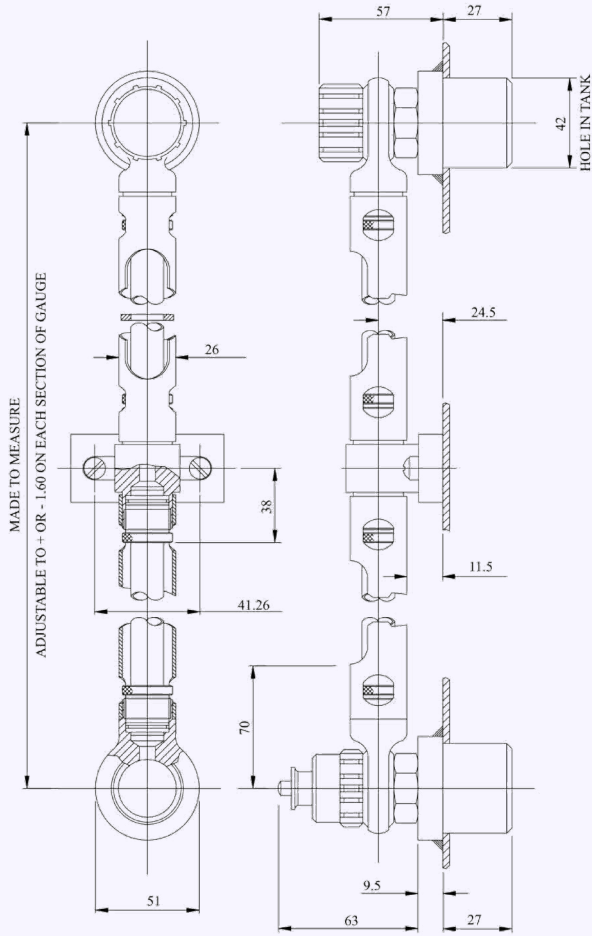

Other Connection Options

THREADED CONNECTION

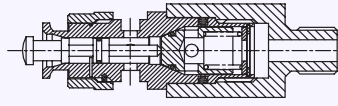

42MM WELD BOSS CONNECTION

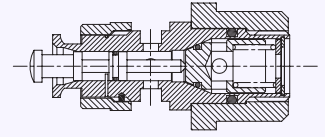

FLANGED CONNECTION

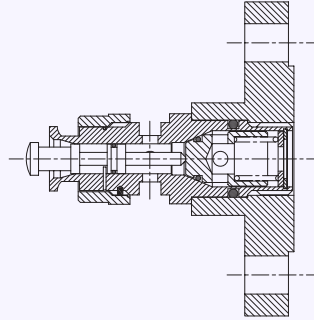

NON-WELD BOSS CONNECTION

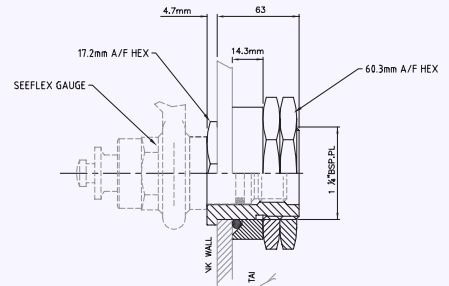

The tank boss is only suitable for use with tanks of wall thickness from 1.58mm (1/16") to 7.9mm (5/16"). hole diameter of 42.0mm is required in the tank wall.

Push-button operation

Except when a reading is being taken, the gauge is permanently isolated from the contents of the tank. To take a reading the spring-loaded valve is opened by pressing a push-button; when released, the connection between the tank and gauge is automatically resealed.

Safe from external damage

Due to the design of the push-button isolation valve, no amount of damage to the gauge or external fittings on the tanks can break the liquid seals. In such an event the fluids cannot escape.

Graduation

Where a measure of the precise storage volume is required, an engraved scale plate can be provided marked with the capacity units.

When ordering please state:

- Distance between gauge centres
- Media identification
- Operating temperature and pressure
- Type of valve units
- Tank connections
- Material of construction

Type G22 Quickmount

The Seetru Quickmount liquid level gauge is a direct reading, tubular design for general industrial use. The unique isolating valve and collar design allows for maintenance of the gauge column without tools and the need to drain the tank. Available with automatic safety shut off valves and drain valve. The construction provides a modern gauge, which is aesthetically pleasing. Suitable for a wide range of pressures and temperatures, the gauge is fitted with elastomer seals in materials to suit the required service.

Example Applications

- Diesel (on-land applications)
- Fuel oil (on-land applications)
- Lubrication oil (on-land applications)
- Water
- Coolant
- Chemicals

Specifications

- Maximum working pressure for Glass Sight Tube: up to 22 bar & 15°C @ 400mm centres
- Maximum working pressure for Polycarbonate Sight Tube: up to 14 Bar & 100°C.
- Maximum Operating Temperature: 150°C (depending on o’ring material)
- Maximum Centre Distance: To suit requirements **
- Minimum Centre Distance – Closed Circuit Design: 150mm
- Minimum Centre Distance – Open Circuit Design: 100mm

** For gauges longer than 1000mm, the column is split into sections using intermediate supports. Each sections maximum length is 1000mm.

Approvals

- Russian Maritime Register of Shipping (RMRS) for non-flammable liquids
- Russian River Register (RRR) for non-flammable liquids
- Conforms with EN BS ISO10088 Recreational Craft Directive

Materials of Construction

Component	Material
Valve Units and Flanges	Brass
	Stainless Steel
	Polypropylene Plastic
Guard Tube	Aluminium
	Stainless Steel
	Brass
	Zinc Plated Mild Steel
Sight Tube	Borosilicate Heat Resisting Glass
	Polycarbonate Plastic



Connection Options

Type	Size
Threaded Connections	1/2" BSP or NPT
	3/4" BSP or NPT
Flanged Connections	DIN Flanges
	ANSI Flanges
Weld Boss	Various Sizes

Other connections available upon request.

Seal Materials

Seal Material	Temperature Range
Nitrile (NBR)	Up to 120°C
Viton (FKM)	Up to 200°C
EPDM	Up to 150°C
Neoprene	Up to 140°C

Other seal materials available upon request.

Design:



Gauge always supplied with a manual screw-down isolation valve at the bottom connection.

The manual screw-down isolation valve is also available with A.S.V. (auto shut off valves). The A.S.V. feature means that in the unlikely event that the glass is damaged, the contents of the tank will not be lost.

Closed Circuit Design

(Connection at top and bottom)

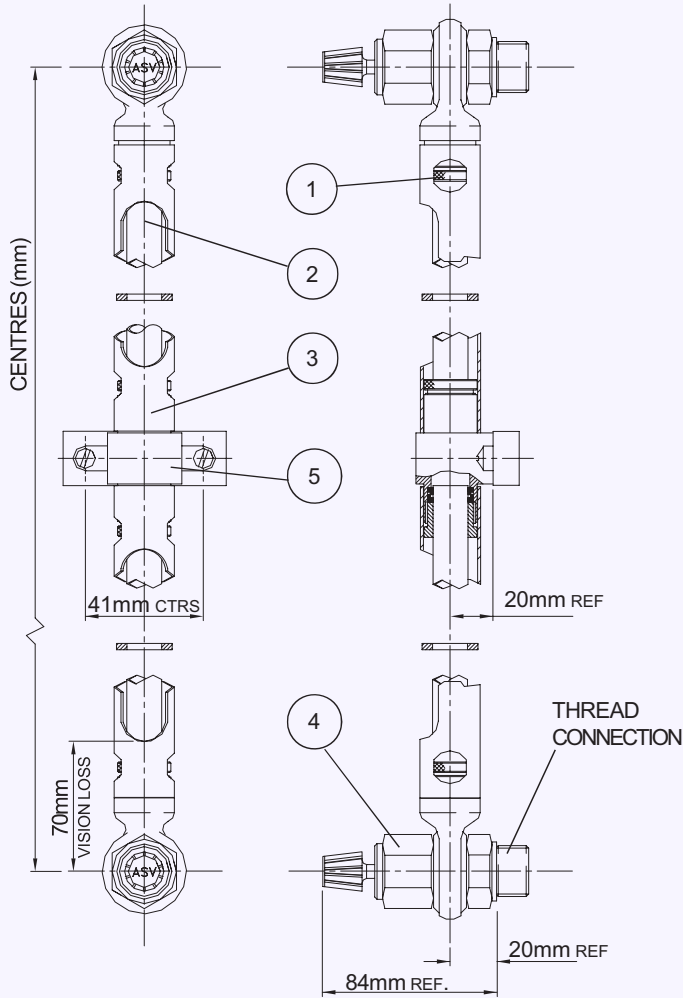

Open Circuit Design

(No top connection)

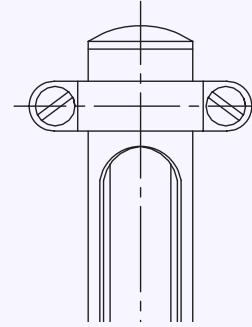

OPEN CIRCUIT

The Quickmount gauge can be supplied with no valve at the top connection.

This is suitable for non-pressurised tanks only.

Other Connections Options

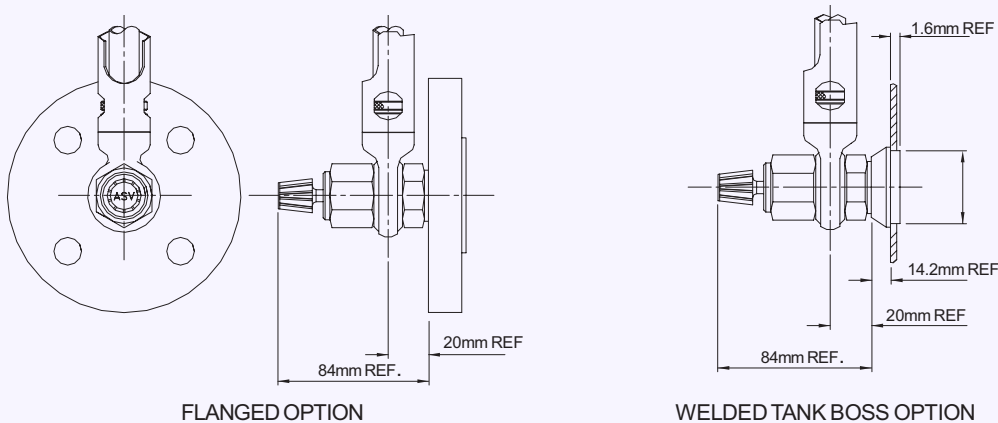



Additional Optionals

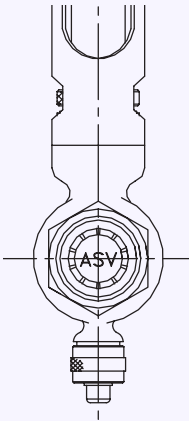

DRAIN/VENT VALVES
Drain and vent valves are available on request.

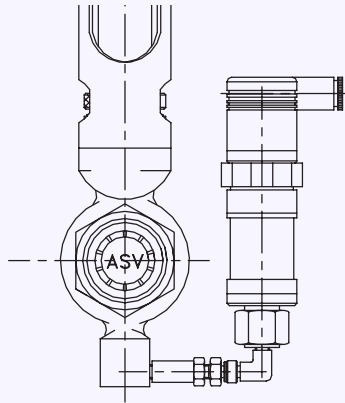

PRESSURE TRANSMITTER/ ELECTRONIC READOUT
The Quickmount gauge is available with a pressure transmitter (normal output of 4-20mA) to enable electronic readout, digital display or computer interface.

BOROSILICATE GLASS SIGHT TUBE

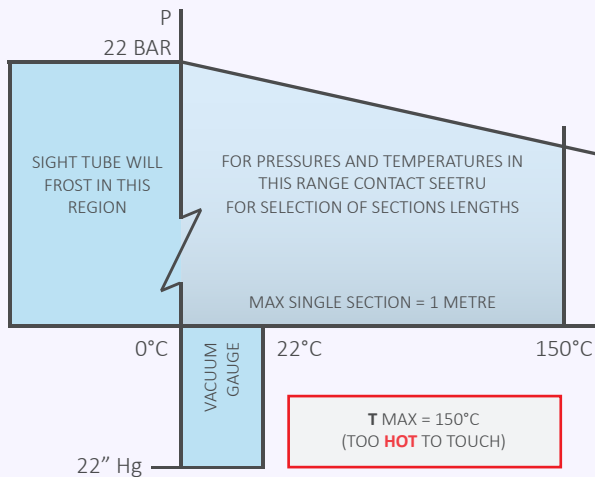

POLYCARBONATE SIGHT TUBE

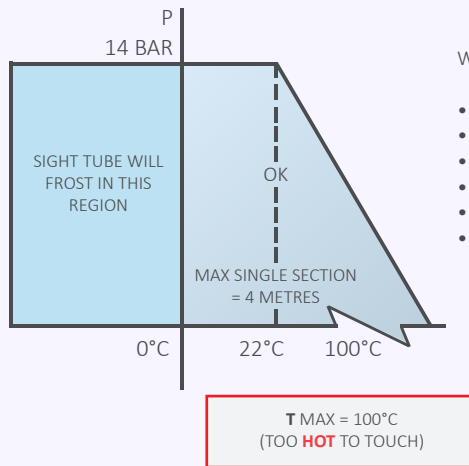

When ordering please state:

- Distance between gauge centres
- Media identification
- Operating temperature and pressure
- Type of valve units
- Tank connections
- Material of construction

The above constraints are approved for water and other non-aggressive liquids only. For any liquid or for any constraint in excess of those given above, please consult Seetru.

Ease Of Installation & Maintenance

The Quickmount liquid level gauge can be installed without the use of special tools. Threaded end Units are screwed into female tank bosses. The gauge collars slip over these Units and are secured by hand tightening retaining nuts. 'O' ring sealing is used throughout. The isolating valves will allow column removal without the need to drain the tank.

Tank Calibration

Where a measure of the precise storage volume is required, an engraved scale plate can be provided, marked with the capacity units.

Electronic & Digital Readout

Remote reading system and/or computer interface options provide a dual system with the advantages of both electronic and sight systems. Level alarms can also be implemented.

Type G23 – CPI Tubular

The Seetru CPI (Chemical and Process Industries) gauge is designed to provide direct level observation of chemicals and solvents. It is a tubular gauge with protective metal guard tube. For applications with higher pressure requirements, or where a more robust design is required, please see the CPI Reflex gauge (G34).

Example Applications

- Chemical storage
- Solvents
- Water
- Coolant
- Oils (on-land)
- Fuel (on-land)
- General liquid storage

Specifications

- Maximum working pressure for Glass Sight Tube: up to 22 bar & 15°C @ 400mm centres
 - Maximum working pressure for Polycarbonate Sight Tube: up to 14 Bar & 100°C.
 - Maximum Operating Temperature: 250°C
 - Maximum Centre Distance: To suit requirements **
 - Minimum Centre Distance – Closed Circuit Design: 150mm
- ** For gauges longer than 1000mm, the column is split into sections using intermediate supports. Each sections maximum length is 1000mm.

Materials of Construction

Component	Material
Valve Units and Flanges	Stainless Steel 316
Guard Tube	Stainless Steel 316
Sight Tube	Borosilicate Heat Resisting Glass
	Polycarbonate Plastic

Seal Materials

Seal Material	Temperature Range
PTFE	Up to 250°C

Connection Options

Type	Size
Flanged Connections	DIN Flanges DN25 to DN50
	ANSI Flanges 1" to 2"

Other connections available upon request.



Glass section pressure/temperature rating

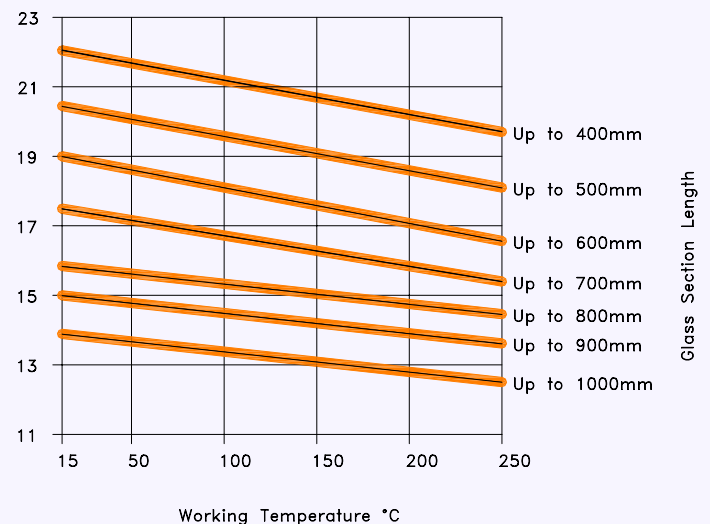

Design:



Purpose designed hand wheel operated isolation valves with A.S.V. (auto shut-off valve) to prevent liquid loss if the glass was to be broken.

Closed Circuit Design

(Connection at top and bottom)

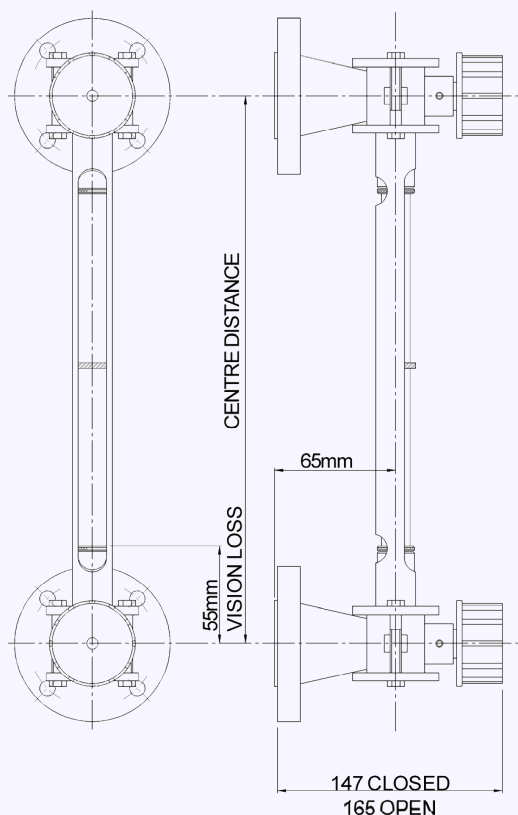

Alternative Fitting

(Drain/Vent Plug)

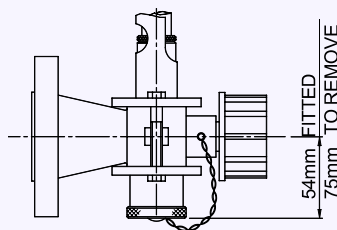

Intermediate Support

(MODEL G231)

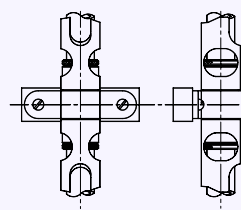

THE MODEL G231 IS SUPPLIED IN A SINGLE SECTION UP TO 1000mm.

Longer columns are supplied with intermediate supports which divide the column into sections, not exceeding 1000mm in each length. A support pad will be required on the tank.

Guard Tube Protection

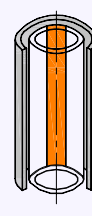

SINGLE SKIN
GUARD G231

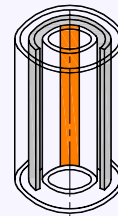

DOUBLE SKIN
GUARD G232

Guard tube model g232 is completely housed in a clear polycarbonate tube (double skin). For additional protection and to prevent spillage, in the event of a glass breakage.

Materials

The CPI tubular gauge is constructed from stainless steel and has P.T.F.E. seals, meaning the gauge is suitable for a wide range of liquids.

Instant dismantling and re-assembly

The CPI gauge tube can be removed from the tank for cleaning or servicing while valves remain sealed and the tank remains leak-proof.

Ease of viewing

The level of colourless liquid is indicated by magnification of a coloured strip on the sight tube.

Graduation

Where a measure of the precise storage volume is required, graduated gauges can be supplied. The capacity units can either be marked on the guard tube or an engraved scale plate can be provided.

Valve options

Sampling valves and drain/vent valves are available upon request.

Column options

For additional protection and to prevent spillage in the event of a glass breakage, this gauge is available with a double guard tube. This consists of the standard metal guard housed in an additional clear polycarbonate outer guard tube.

Electronic & digital readout

Remote reading system and/or computer interface options provide a dual system with the advantages of both electronic and sight glass systems. Level alarms can also be implemented.

Type G27 Mini Gauge

The Seetru Mini gauge is a simple but effective tubular liquid level gauge. It has valveless end connections that screw directly into the tank and is commonly used for small water tanks and compressor lube oil tanks, but can be used for a variety of other fluids as it can be supplied with a choice of end unit, sight tube and seal materials.

If you require a tubular level gauge with isolation valves please see either the Quickmount (G22) or the CPI (G23) gauges

Example Applications

- Water
- Coolant
- Chemicals
- Lubrication oil
- General liquid storage

Specifications

- Standard maximum working pressure: 19 bar*
- High pressure version available upon request up to 30 bar
- Maximum Operating Temperature: 180°C (depending on o’ring material)
- Maximum Centre Distance: 1000mm
- Minimum Centre Distance – Closed Circuit Design: 125mm
- Minimum Centre Distance – Open Circuit Design: 100mm

Materials of Construction

Component	Material
End Units	Brass
	Nickel Plated Brass
	Stainless Steel
Guard Tube	Polycarbonate Plastic
	Stainless Steel
Sight Tube	Borosilicate Heat Resisting Glass
	Polycarbonate Plastic

Seal Materials

Seal Material	Temperature Range
Nitrile (NBR)	Up to 120°C
Viton (FKM)	Up to 180°C
EPDM	Up to 150°C
Neoprene	Up to 140°C

Other seal materials available upon request.

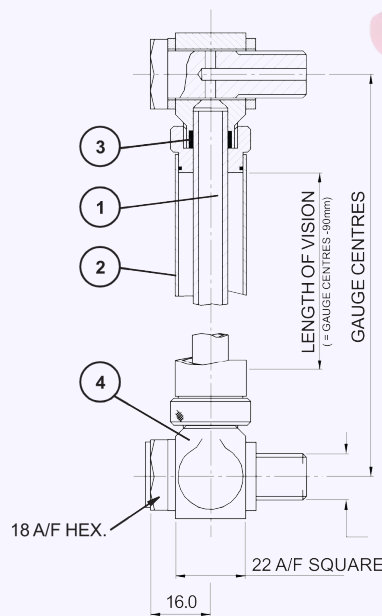

Connection Options

Type	Size
Threaded Connections	1/4" BSP Parallel
	M12
	1/2"-20 UNF

Type G31 Seeflex

The Seetru Seeflex Gauge is designed for use within the marine & offshore industries for tanks containing flammable liquids. The Seeflex gauge meets the requirements of SOLAS (Safety of Lives at Sea). This gauge is commonly used on cargo ships and work boats.

Example Applications

- Diesel
- Fuel oil
- Aviation fuel
- Lubrication oil
- Water
- Coolant

Specifications

- Maximum Operating Pressure: 2.67 bar
- Maximum Operating Temperature: 80°C
- Minimum Operating Temperature: -35°C
- Minimum Centre Distance – Closed Circuit Design: 358mm
- Minimum Centre Distance – Open Circuit Design: 315mm

Materials of Construction

Component	Material
Front Bezel	Black Coated, Rust Protected Mild Steel
	Stainless Steel
Back Channel	Stainless Steel
Valve Bodies / End Units	Brass
	Stainless Steel
Reflex Glass	Hardened Borosilicate

Seal Materials

O-ring material – Top cap	Temperature Range
Nitrile (NBR)	-35°C to +80°C

Other seal materials available upon request.

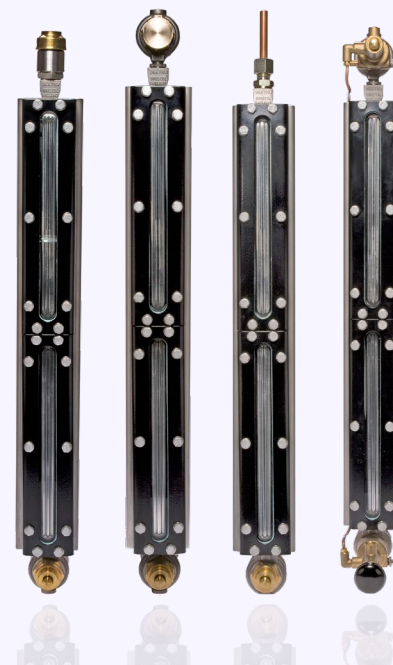

Approvals

- Det Norske Veritas (DNVGL),
- Lloyds Register of Shipping (LR)
- Russian Maritime Register of Shipping (RMRS)
- Russian River Register (RRR)
- American Bureau of Shipping (ABS)
- Bureau Veritas (BV)
- RINA
- Nippon Kaiji Kyokai (Class NK)

Meets the requirements of SOLAS (Safety of Lives at Sea)

Connection Options

Type	Size
Weld Bosses	42mm Weld Boss
Threaded Connections	G1/2" BSP male
	G3/4" BSP male
Flanged Connections	DN20 PN16
	DN25 PN16
	3/4" ANSI 150
	1" ANSI 150
Non-Weld Boss	42mm

Other connections available upon request.



Gauge always supplied with Push-button Isolation Valve at the bottom connection

With 42mm Weld Bosses

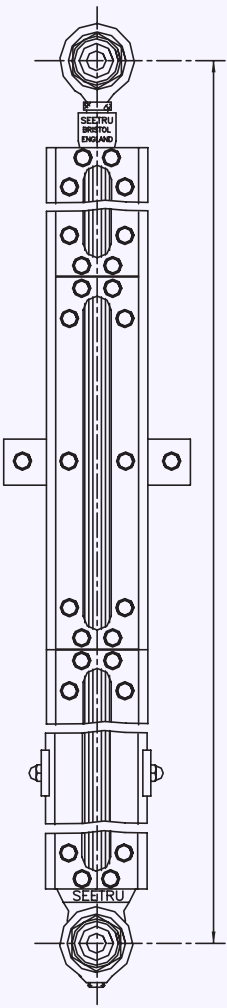

With Flanged Connections

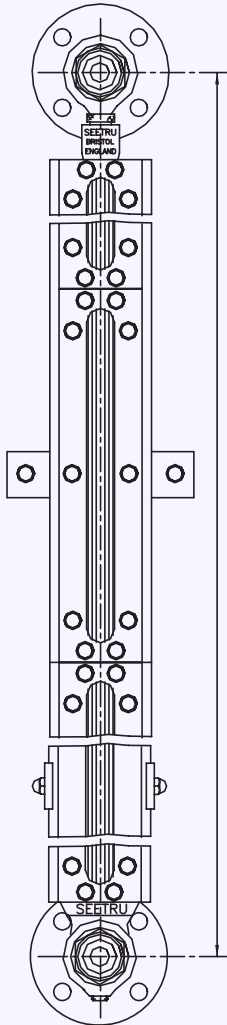

Closed Circuit Design Top Fittings

Self Closing Pushbutton Isolation Valve

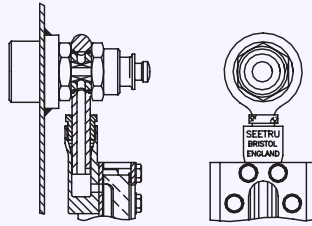

Closed Circuit Design

(Top Of Gauge Must Be Min. 100mm Above Tank Top) Automatic Safety Vent Valve

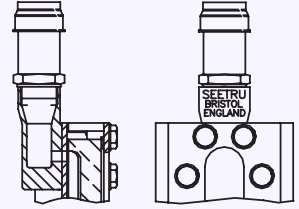

Valveless Tank Return

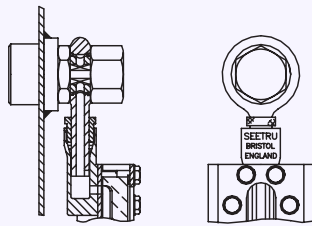

Pipe Union Connection

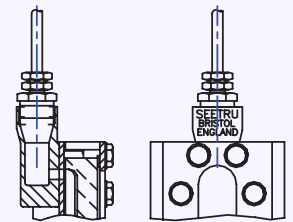

Connection Options

Threaded Connection

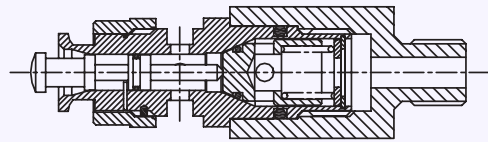

42mm Weld Boss Connection

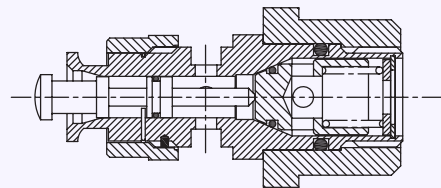

Non-Weld Boss Connection

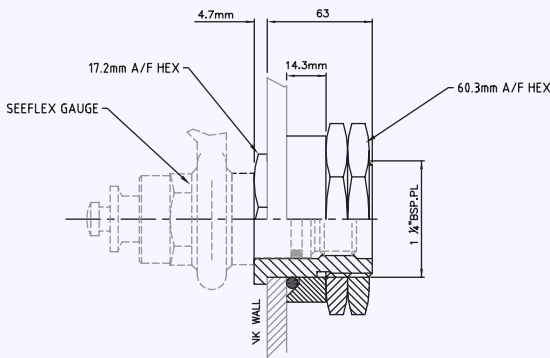

The tank boss is only suitable for use with tanks of wall thickness from 1.58mm (1/16") to 7.9mm (5/16") hole diameter of 42.0mm is required in the tank wall.

Flanged Connection

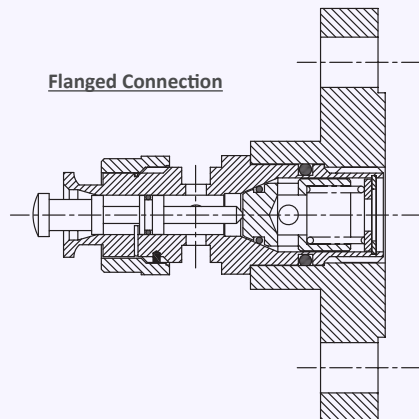



HYDRAULIC ACTUATION

The hydraulic actuation allows the operation of more than one valve from the same location, In the case of the integral system, both valves will be mounted on the same gauge- this is used mainly for longer gauges that exceed 1000mm centres. The remote system allows the operation of up to 4 valves on various gauges from the same location.

Integrated Hydraulic Actuation

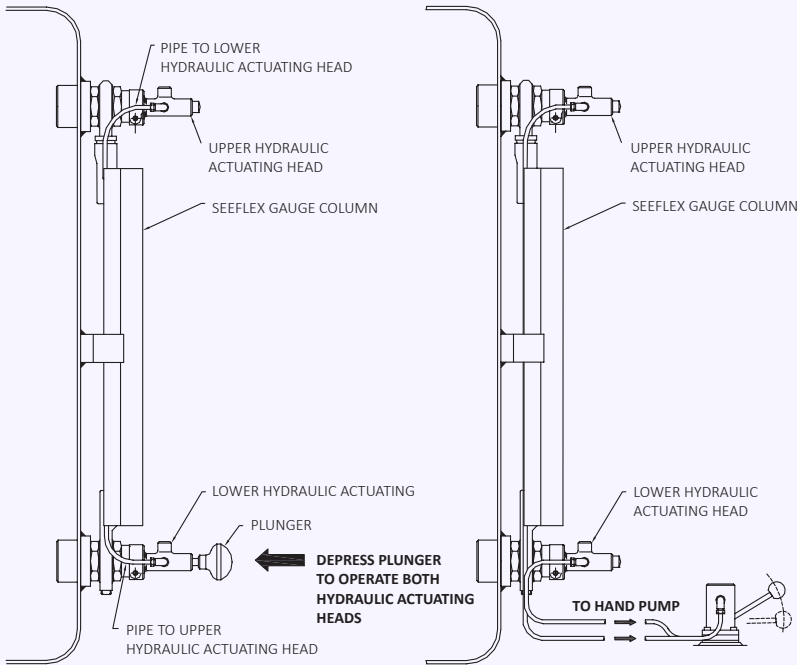

Remote Hydraulic Actuation

Push-button operation

Except when a reading is being taken, the gauge is permanently isolated from the contents of the tank. To take a reading the spring-loaded valve is opened by pressing a Push-button. When released, the connection between the tank and gauge is automatically resealed.

Safe from external damage

Due to the design of the push-button isolation valve, no amount of damage to the gauge or external fittings on the tanks can break the liquid seals. In such an event the fluids cannot escape.

Closed circuit design

The closed circuit design penetrates the tank wall at both top and bottom connections. The options for the top connection are either a push-button self-closing valve or valve less tank return.

Open circuit design

This is only allowable when it is possible for the gauge column to extend above the top of the tank by at least 100 mm. The upper end of the gauge can be supplied with an automatic safety vent valves or, alternatively, a pipe union connection. The automatic safety vent will allow air to pass, but will seal against a liquid level. In the case of the pipe union connection design, a 10 mm o/d steel vent pipe is returned to the tanks or into the tank vent pipe.

Graduation

Where a measure of the precise storage volume is required, an engraved scale plate can be provided marked with the capacity units.

Column Supports

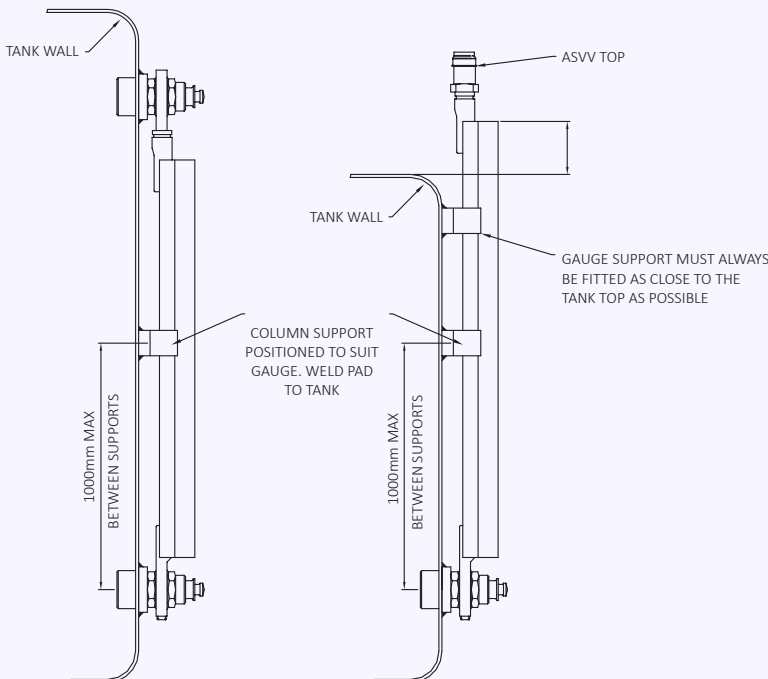

Gauges that have a centre distance greater than 1000mm and open circuit gauges, will be supplied with a column support, so that the gauge can be fixed to the tank wall. The maximum distance between the gauge fixings and a column support or between two column supports should be 1000mm, in the case of open circuit gauges the top most column support should be fitted as close to the tank top as possible.

Number of isolating valves	Total allowable length of piping
1	60 metres
2	30 metres
3	20 metres
4	15 metres

Type G32 Quickflex

The Seetru Quickflex gauge is a flat glass level gauge which offer enhanced column protection over and above a tubular glass gauge. Please note – the Quickflex gauge is not type approved for use with flammable liquids for shipbuilding applications, if you require gauge with marine type approvals please see the G31 Seeflex gauge and the G35 Seemag gauge.

Example Applications

- Diesel/fuel oil (on land only – if for shipbuilding see G31 Seeflex gauge and the G35 Seemag gauge)
- Chemicals
- Water
- Coolant

Specifications

- Maximum Operating Pressure: 3.25 bar
- Maximum Operating Temperature: 100°C
- Minimum Centre Distance – Closed Circuit Design: 358mm
- Minimum Centre Distance – Open Circuit Design: 315mm

Approvals

The Quickflex gauge is not type approved for use with flammable liquids for shipbuilding applications, if you require gauge with marine type approvals such as LR, DNV, BV, ABS etc, please see the G31 Seeflex gauge and the G35 Seemag gauge.

Materials of Construction

Component	Material
Front Bezel	Black Coated, Rust Protected Mild Steel
	Stainless Steel
Valve Bodies / End Units	Stainless Steel
Sight Tube	Brass
	Stainless Steel
Weld Bosses / Flanges	Hardened Borosilicate



Seal Materials

Seal Material	Temperature Range
Nitrile (NBR)	-35°C to +100°C
Viton (FKM)	-15°C to +100°C

Other seal materials available upon request.

Connection Options

Type	Size
Threaded Connections	1/2" BSP or NPT
	3/4" BSP or NPT
Flanged Connections	DIN Flanges
	ANSI Flanges
Weld Boss	42mm OD

Other connections available upon request.



Gauge always supplied with manual screw down isolation valve at the bottom connection, the 3/4" valve is available with auto shut-off valve to seal the tank in case of damage to the gauge column.

With Threaded Connections

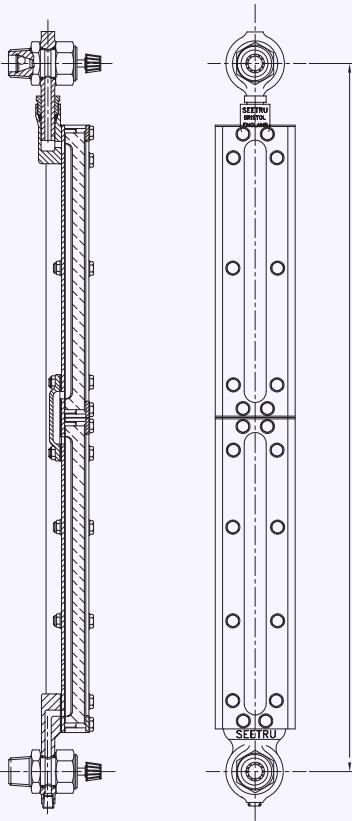

With Flanged Connections

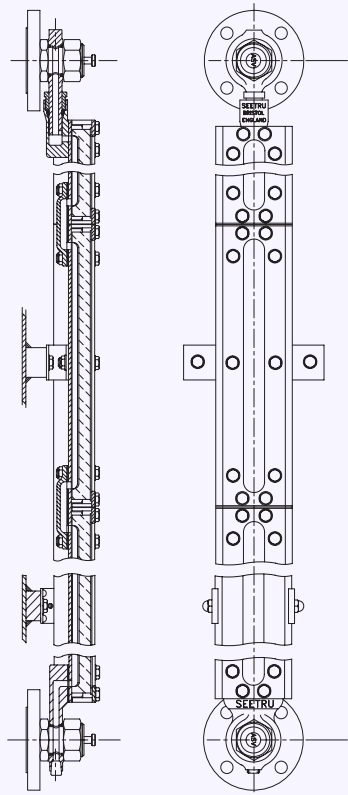

Closed Circuit Design Top Fittings

Manual screw down isolation valve
(3/4" version available with auto shut-off)

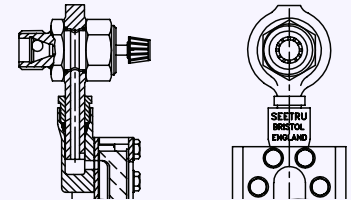

Valveless tank return

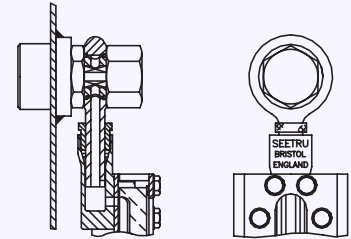

Closed Circuit Design Top Fittings

(TOP OF GAUGE MUST BE MIN. 100mm ABOVE TANK TOP)

Pipe Union Connection

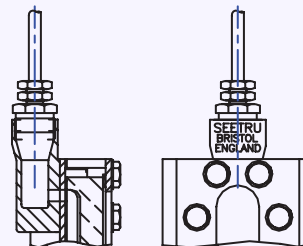

Automatic Safety Vent Valve

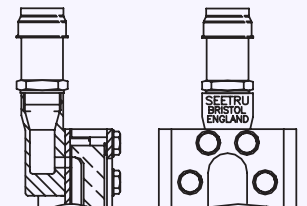

Closed circuit design.

The closed circuit design penetrates the tank wall at both top and bottom connections. The options for the top connection are either a manual screw down isolation valve or valve less tank return. The 3/4" screw down valve is available with auto shut-off.

Open circuit design

This is only allowable when it is possible for the gauge column to extend above the top of the tank by at least 100 mm. The upper end of the gauge can be supplied with an automatic safety vent valves or, alternatively, a pipe union connection. The automatic safety vent will allow air to pass, but will seal against a liquid level. In the case of the pipe union connection design, a 10 mm o/d steel vent pipe is returned to the tanks or into the tank vent pipe.

Graduation

Where a measure of the precise storage volume is required, an engraved scale plate can be provided marked with the capacity units.

Type G33 Refrigeration Reflex Gauge

The G33 Refrigeration Reflex Gauge is a heavy duty (flat glass) liquid level gauge, suitable for refrigeration liquids. The modular design is made up of compact and robust standard stainless steel precision cast elements.

Refrigerant industry isolating valves are available in a number of flexible configurations offering end mounted, side mounted, rear entry connections, with full centre to centre visibility can be secured with minimum overall length.

Example Applications

- Refrigeration chillers
- Refrigeration vessels
- Industrial refrigeration
- Ammonia refrigeration

Specifications

- Maximum working pressure: 25 bar (depending on temperature and flanges)
- Maximum Operating Temperature: 100°C
- Minimum Operating Temperature: 0°C (without frost guard)
- For temperatures below 0°C to -30°C a frost guard is required
- Maximum Centre Distance: To suit requirements, gauges built in sections using No. 6 and No. 9 Reflex glass
- Minimum Centre Distance – 216mm (rear mounted/side mounted), 348mm (straight mounted)

Materials of Construction

Component	Material
Valve Units	Plated Mild Steel or Stainless Steel
Gauge Chamber	Stainless Steel
Glass	Borosilicate Reflex Glass BS3463
Glass To Chamber Seal	Asbestos Free Gasket
Valve O-ring Material	Elastomer Rubber - Choice of Materials

Frost Guard

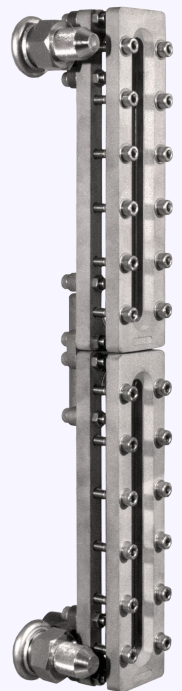
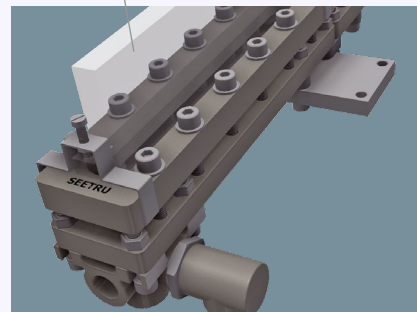

Seal Materials

Seal Material	Temperature Range
Nitrile (NBR)	Up to 100°C
Viton (FKM)	Up to 100°C
EPDM	Up to 100°C
Neoprene	Up to 100°C

Other seal materials available upon request.

Connection Options

Type	Size
Threaded Connections	BSP thread 1/2" or 3/4"
	NPT thread 1/2" or 3/4"

Other connections available upon request.



Design:

The G33 Reflex gauge is a heavy duty (flat glass) liquid level gauge, suitable for refrigeration applications. The modular design is made up of compact and robust standard stainless steel precision cast elements and uses No. 6 and No. 9 size Reflex glass.

The isolation valves are manual screw down valves with auto shut-off valves.

Column arrangements:

The Reflex gauge is available with either a straight or staggered column, and a choice of valve positions, to provide uninterrupted centre to centre liquid level indication. With the use of extension pieces most centre to centre distance requirements can be achieved.

Graduation:

Where a measure of the precise storage volume is required an engraved scale plate can be provided marked with the capacity units.

Inline Column Options:

Ball valves with Threaded Connections:

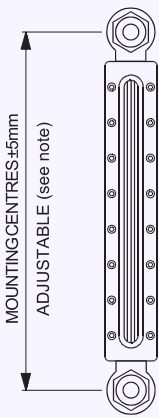

STRAIGHT MOUNTED

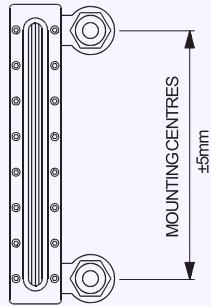

SIDE MOUNTED

ISOLATING VALVES SIDE MOUNTED
(EQUAL TO LENGTH OF VISION)

Offset Column Options:

Provides uninterrupted viewing over the entire mounting centres.

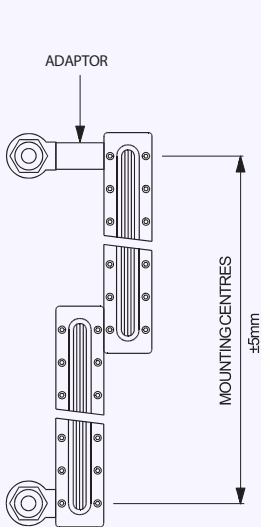

STRAIGHT MOUNTED

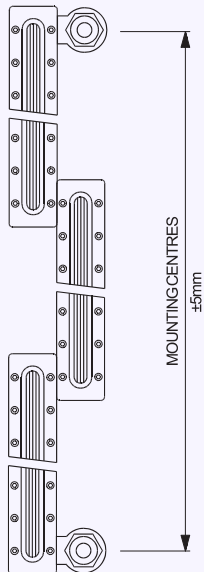

SIDE MOUNTED

Type G34B Reflex Gauge

The G34 Reflex gauge is a heavy duty (flat glass) liquid level gauge, suitable for high pressure/temperature combinations. The modular design is made up of compact and robust standard stainless steel precision cast elements.

Variations on the isolating valves ranging from quarter turn ball valves to heavy duty hand wheel isolating valves complete with auto safety shut off safety features are available in a number of flexible configurations offering end mounted, side mount, rear entry connections, with full centre to centre visibility can be secured with minimum overall length.

Example Applications

- Diesel (on land applications)
- Fuel oil (on land applications)
- Lubrication oil (on land applications)
- Water
- Coolant
- Chemicals
- Hot water/steam

Specifications

- Maximum working pressure: 75 bar (depending on temperature and flanges)
- Maximum Operating Temperature: 250°C (depending on pressure)
- Minimum Operating Temperature: 0°C (without frost guard)
- For temperatures below 0°C to -30°C a frost guard is required
- Maximum Centre Distance: To suit requirements, gauges built in sections using No. 6 and No. 9 Reflex glass
- Minimum Centre Distance – 216mm (rear mounted/side mounted), 348mm (straight mounted)

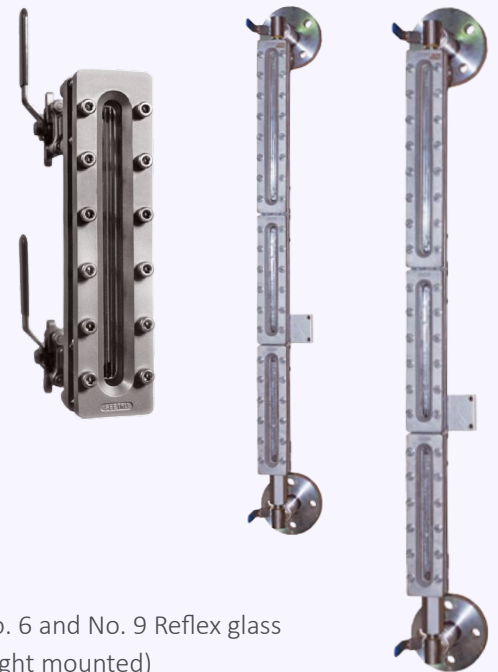

Materials of Construction

Component	Material
Valve Units (Flanges If Required)	Stainless Steel
Gauge Chamber	Stainless Steel
Glass	Borosilicate Reflex Glass BS3463
Glass to Chamber Seal	Asbestos Free Gasket

Seal Materials

Seal Material	Temperature Range
PTFE	High Pressure up to 150°C
PTFE	Low Pressure up to 250°C
Polyimide	High Pressure Between 150°C and 250°C

Other seal materials available upon request.

Connection Options

Type	Size
Threaded Connections	BSP Thread 1/2", 3/4" or 1"
	NPT Thread 1/2", 3/4" or 1"
Flanged Connections	DIN Flanges DN20 to DN50
	ANSI Flanges 3/4" to 2"

Other connections available upon request.



Design:

The G34B Reflex gauge is a heavy duty (flat glass) liquid level gauge, suitable for high pressure/temperature combinations. The modular design is made up of compact and robust standard stainless steel precision cast elements and uses No. 6 and No. 9 size Reflex glass.

Column arrangements:

The Reflex gauge is available with either a straight or staggered column, and a choice of valve positions, to provide uninterrupted centre to centre liquid level indication. With the use of extension pieces most centre to centre distance requirements can be achieved.

Graduation:

Where a measure of the precise storage volume is required an engraved scale plate can be provided marked with the capacity units.

Inline Column Options:

Ball valves with Threaded Connections:

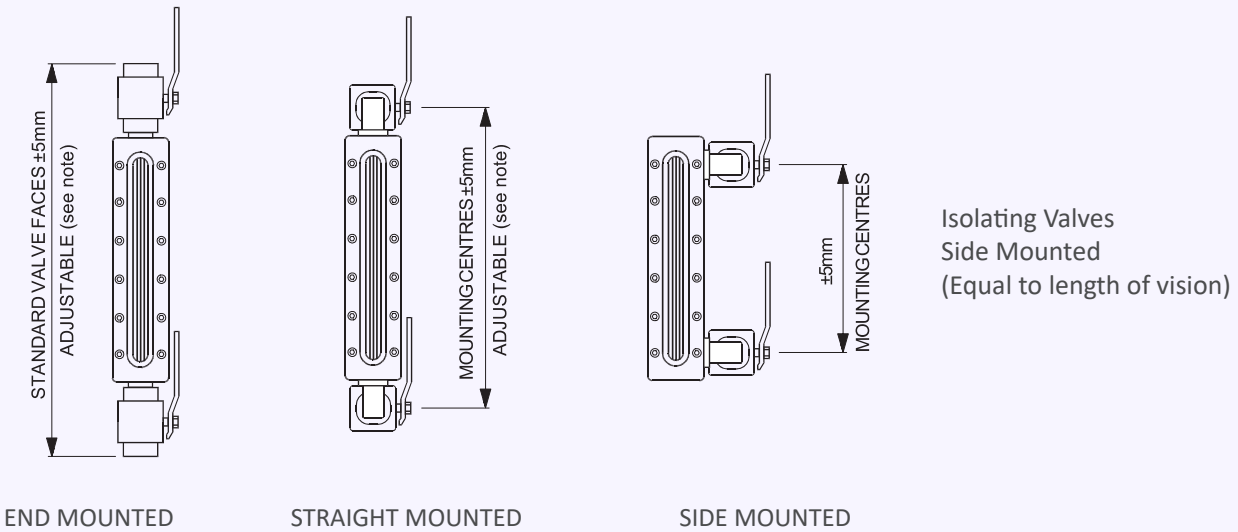

Inline Column Options:

Ball valves with Flanged Connections

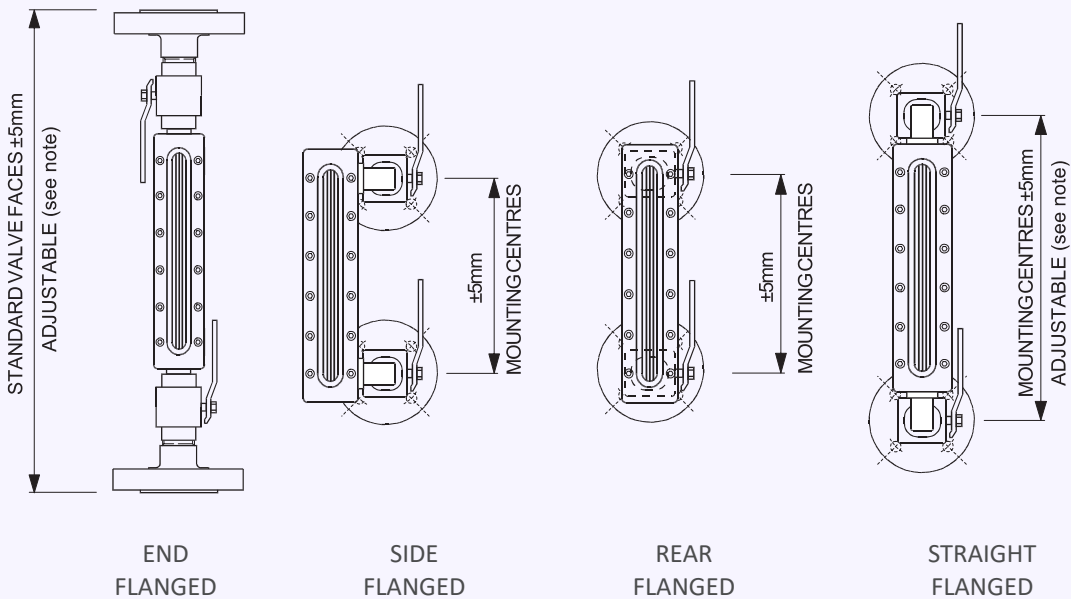



Offset Column Options:

Ball valves with Threaded Connections:

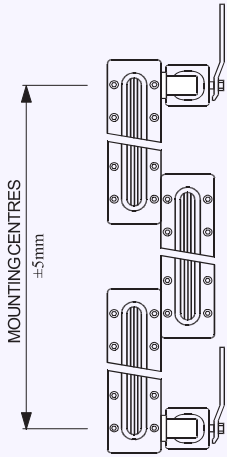

STRAIGHT MOUNTED

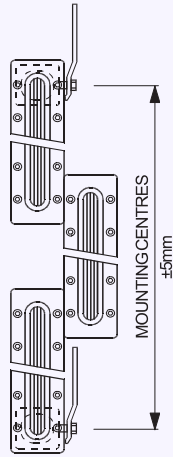

REAR MOUNTED

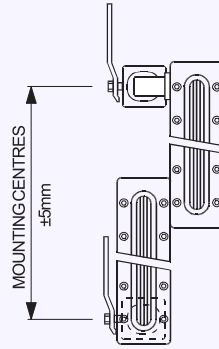

SIDE/REAR MOUNTED

(When an even number of column sections are required use 1 rear & 1 side mounted valve, For odd number of columns use either 2 rear or 2 side mounted valves).

Ball valves with Flanged Connections

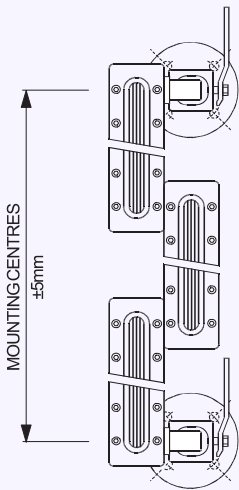

SIDE MOUNTED

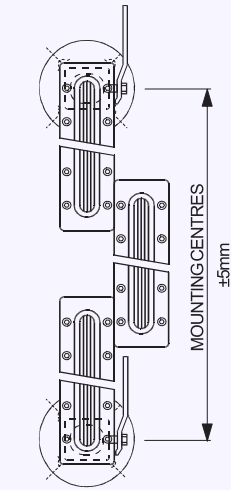

REAR MOUNTED

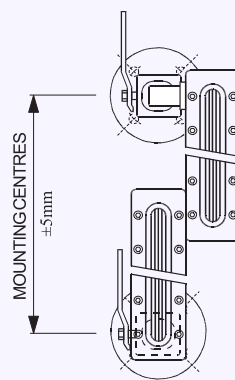

SIDE/REAR MOUNTED

(When an even number of column sections are required use 1 rear & 1 side mounted valve, For odd number of columns use either 2 rear or 2 side mounted valves).

Type G34C CPI Reflex Gauge

The heavy duty Seetru CPI (Chemical and Process Industries) Reflex Gauge is a flat glass gauge designed to provide direct level observation of chemicals and solvents. It is suitable for high pressure / temperature combinations. The modular design is made up of compact and robust standard stainless steel precision cast elements.

The G34C Reflex gauge is fitted with heavy duty hand wheel isolating valves complete with auto safety shut off safety features. These gauges are available in a number of flexible configurations offering end mounted, side mount, rear entry connections, with full centre to centre visibility which can be secured with minimum overall length.

Example Applications

- Chemicals
- Solvents
- Diesel (on land applications)
- Fuel oil (on land applications)
- Lubrication oil (on land applications)
- Water
- Coolant
- Hot water/steam

Specifications

- Maximum working pressure: 35 bar (depending on temperature and flanges)
- Maximum Operating Temperature: 250°C (depending on pressure)
- Minimum Operating Temperature: 0°C (without frost guard)
- For temperatures below 0°C to -30°C a frost guard is required
- Maximum Centre Distance: To suit requirements, gauges built in sections using No. 6 and No. 9 Reflex glass
- Minimum Centre Distance – 216mm (rear mounted/side mounted), 348mm (straight mounted)



Materials of Construction

Component	Material
Valve Units & Flanges	Stainless Steel
Gauge Chamber	Stainless Steel
Glass	Borosilicate Reflex Glass BS3463
Glass to Chamber Seal	Asbestos Free Gasket

Seal Materials

Seal Material	Temperature Range
PTFE	Up to 250°C

Other seal materials available upon request.

Connection Options

Type	Size
Flanged Connections	DIN Flanges DN20 to DN50
	ANSI Flanges 3/4" to 2"

Other connections available upon request.

Inline Column Options:

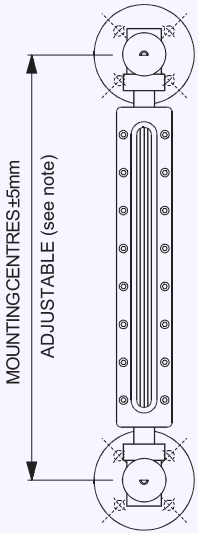

STRAIGHT MOUNTED

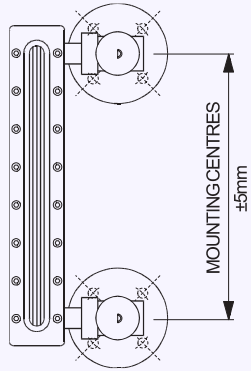

ISOLATING VALVES SIDE MOUNTED
(EQUAL TO LENGTH OF VISION)

SIDE MOUNTED

Offset Column Options:

Provides uninterrupted viewing over the entire mounting centres.

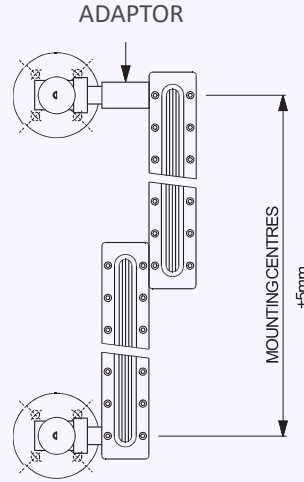

SIDE MOUNTED EVEN

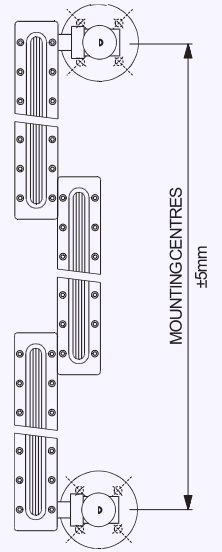

SIDE MOUNTED ODD

Inline Column Options:

130mm Nominal

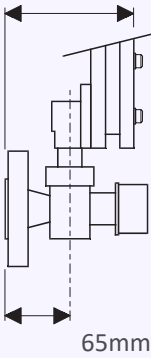

STANDARD C.P.I.
VALVE

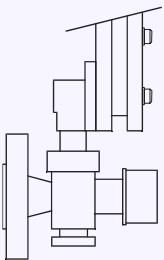

SAMPLER / DRAIN
VALVE

G35 Seemag Magnetic Gauge

The Seetru Seemag® tank content indicator or gauge is a high quality yet economical magnetic level indicator. Its unique design offers considerable advantages over conventional magnetic gauges including accurate step-less reading with all round visibility and the option of high/low level alarms with remote digital reading.

The gauge utilises a marker strip on a movable carriage fitted on the outside of a stainless steel tube, which by way of magnets moves up and down in unison with a float inside the tube. The marker strip is adjustable to suit the specific gravity of the liquid to be measured.

Example Applications

- Diesel
- Fuel oil
- Heavy fuel oil (heating may be required)
- Lubrication oil
- Water
- Coolant
- Chemicals

Specifications

- Maximum Operating Temperature: 180°C
- Minimum Centre Distance: 450mm, Maximum Centre Distance: 5000mm
- Specific gravity: 0.7 – 1.3 (using different floats)
- Maximum kinematic viscosity: 40mm²/s (Indicator is suitable for more viscous fluids if supplied with trace heating)

Materials of Construction

Component	Material
By-Pass Tube	Stainless Steel 316
Front Guard	Polycarbonate
Rear Guard	Aluminium Alloy
Collars & Connections	Stainless Steel 316
Float	Stainless Steel 316
Level Indicator & Follower	Polypropylene & Nylon

- Isolation ball valves are available upon request.
- Drain & vent valves available upon request.
- Graduation – A clear scale is included on the front guard, marked in mm and cm.

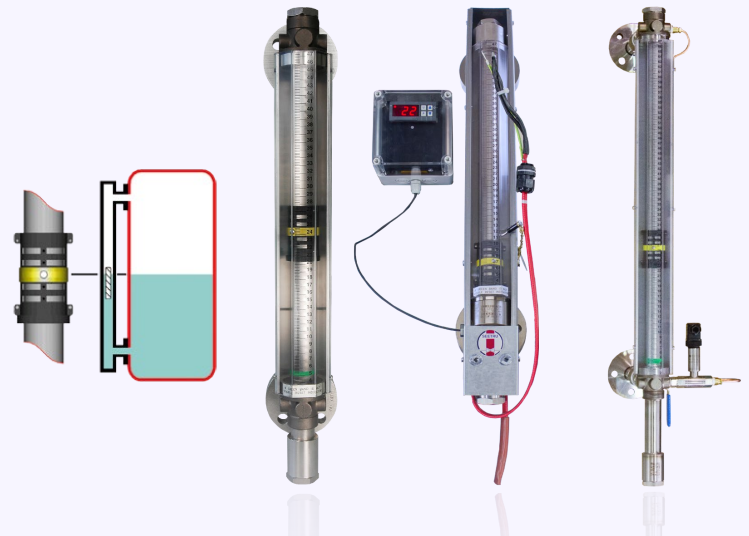

Approvals

- Det Norske Veritas (DNVGL),
- Lloyds Register of Shipping (LR)
- American Bureau of Shipping (ABS)
- RINA

Meets the requirements of SOLAS (Safety of Lives at Sea)

Connection Options

Type	Size
Flanged Connections	DN15, DN20, DN25, DN32, DN40 or DN50 PN16 or PN40 DIN Flanges
	1/2", 3/4", 1", 1 1/2" or 2" #150 or #300 ANSI Flanges
Threaded Connections	1/2", 3/4", 1" BSP Thread
	1/2", 3/4" or 1" NPT Thread
Non-Weld Boss	30mm OD Stub Pipe (other sizes may be available upon request)

Standard connection options shown, other connections may be available upon request.

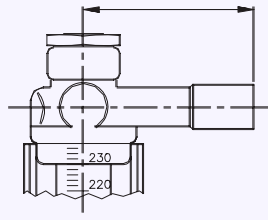
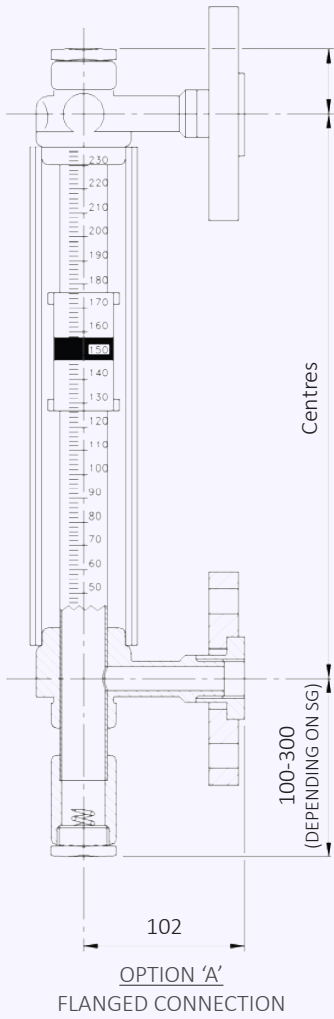

OPTION 'B'
STUB PIPE FOR WELDING
MINIMUM O/D 20mm

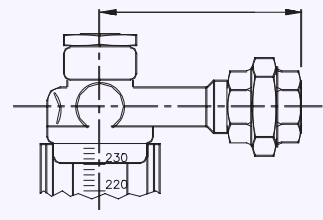

OPTION 'C'
UNION CONNECTIONS
* DEPENDING ON CONNECTION SIZE

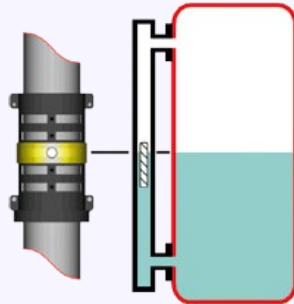

Options: *Pressure Transmitter and Digital Readout*

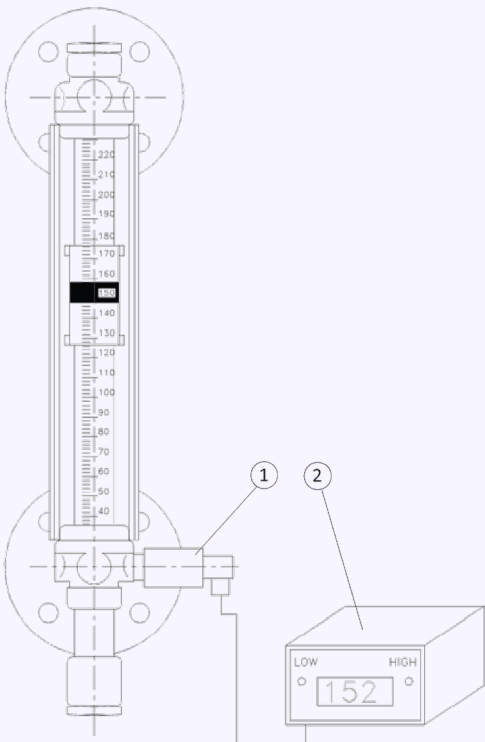

Pressure Transmitter

[Marine & intrinsically safe versions available]

Standard pressure transmitter should only be used on atmospheric tanks.
Differential pressure transmitter to be used on pressurised tanks.

The pressure transmitter works independently from the Seemag and can be used for continuous reading and switching points.

- Output signal: 4-20mA
- Supply voltage: 12-28 Vdc
- Operating temperature range:
- Ambient: -25 +85°C
- Fluid: -25 +100°C

Digital Readout (Optional)

Digital linearised panel meter which requires a DC current.
This unit usually operates with an analogue pressure transducer.
High & low switching points incorporated within panel meter.

- Transmitter input: 4-20mA
- Power supply: 240Vac 50Hz
- Internal supply: 24V to power transmitter
- Environmental: Operating temp. 0-50°C

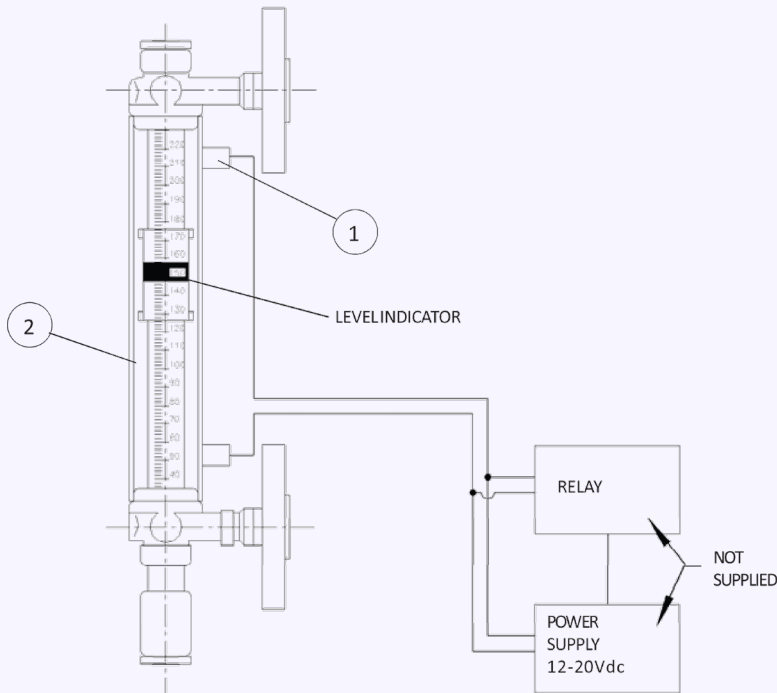

SWITCHING OPERATION

Level switches are of a magnetic hall effect design. Switches are operated when the magnet in the base of the level indicator passes the switch, in either direction, causing it to be in one or the other state.

A power supply and relay are required to operate the switches (not supplied). Relays can then be terminated to pumps, alarms, switches or to a PC interface.

Switches are attached to rear guard tube and can be moved up or down to suit the required switching point. Two switches are shown, but any number can be supplied.

TECHNICAL SPECIFICATION

Switches require a 12-20 VDC supply and suitable relay.
 For suggested supply and relay combinations, contact Seetru.
 Max. load current: 250mA
 Operating conditions: 0-60°C

Trace Heating: *(There are three (3) trace heating options available).*



1) Electric Heating:

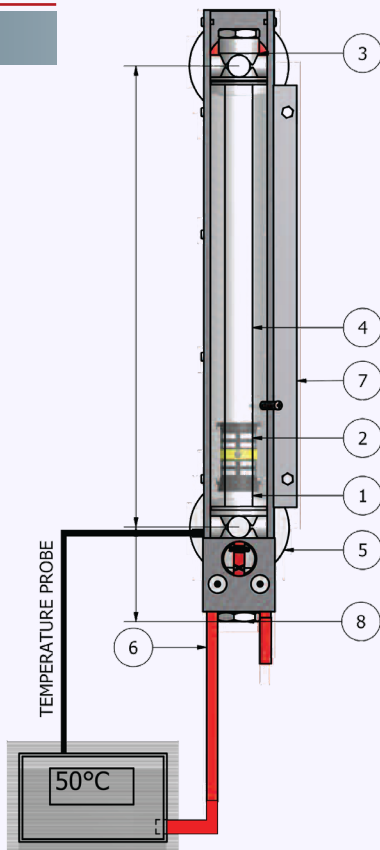

ELECTRIC TRACE HEATING

A continuous loop of 60 W/metre trace heating cable is attached to the rear guard tube of the indicator.

The cable is terminated at one end to a control box which can be used to regulate the temperature in the indicator via a temperature probe.

CONTROL BOX

Voltage supply 220-240V
 With temperature display and probe.



2) Steam Heating:

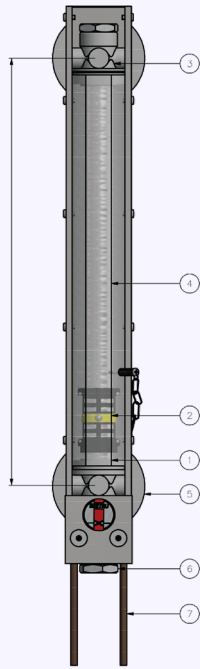

STEAM HEATING

8mm O/D Copper tube is attached to the rear guard tube in a continuous loop, from the bottom of the indicator.

The enclosure is then fitted around the indicator to protect the copper tube.

STEAM CAN BE FED THROUGH THE PIPE TO HEAT THE LIQUID IN THE BY-PASS TUBE.

EXAMPLE

- Ambient air temperature = 20°C
- Steam pressure 1.5 bar = 68°C Liquid temperature
- Steam pressure 3 bar = 85°C Liquid temperature

NOTE

MAXIMUM WORKING TEMPERATURE SHOULD NOT EXCEED 180°C

3) Thermal Oil Heating:

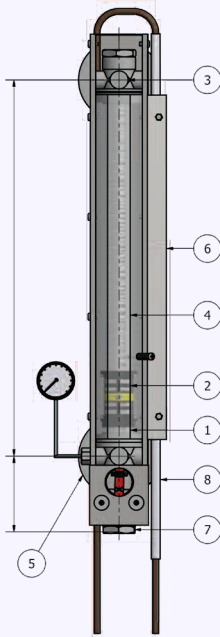

THERMAL OIL HEATING

The Thermal heating system comprises of: 8mm O/D copper tube fed around the rear of the gauge, when thermal heating oil is fed through the tube this heats the fluid inside the indicator.

This is all encased in a protective steel enclosure. Fitted with a temperature gauge so the fluid temperature can be monitored.

Bottom connection dimensions:



MATRIX 5TH DIGIT	S.G	BOTTOM CAP (A)	BOTTOM DRAIN & CAP (B)
1	0.7 - 0.8	301mm	389mm
2	0.8 - 0.9	202mm	290mm
3	0.9 - 1.1	136mm	224mm
4	1.1 - 1.3	103mm	191mm

Type SF & SG Window Sight Glasses

Seetru circular window sight glasses are compact low cost assemblies that provide reliable level indication and positive indication when liquid is present. These screw-in plugs are fitted with high quality glass. They are suitable for a wide variety of liquids including water, oils and lubricants. They operate at temperatures up to 180°C and pressures up to 24 bar.

Seetru Circular Window Sight Glasses are, for example, widely used in compressor crank cases and other machine housings and have proved to be highly reliable and economic.

Example Applications

- Water
- Coolant
- Chemicals
- Lubrication oil
- General liquid storage

Specifications

- Standard maximum working pressure: Up to 24 bar (depending on size/glass, see pressure table).
- Maximum Operating Temperature: 180°C (depending on O-ring material).

Materials of Construction

Component	Material
Body	Mild Steel (Zinc Plated)
	Stainless Steel (316)
Seal	To Suit Application- See O-ring Options
Glass Window	Sizes 1/2", 3/4" & 1" = Annealed Borosilicate Glass
	Sizes 1 1/4", 1 1/2" & 2" = Toughened Soda Lime Glass

Seal Materials

O'ring material – Top cap	Temperature Range
Nitrile (NBR)	Up to 120°C
Viton (FKM)	Up to 180°C
EPDM	Up to 150°C
Neoprene	Up to 140°C

Other seal materials available upon request.

SERIES 'SF'

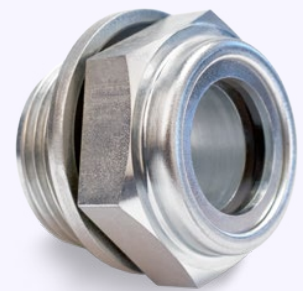
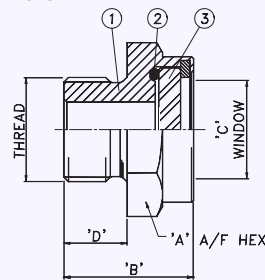

SERIES 'SG'

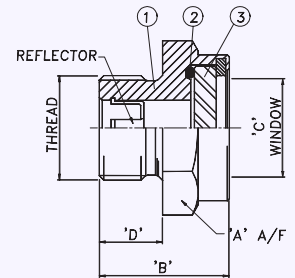

Connection Options

Type	Size
Threaded Connections	BSP Parallel
	NPT
	Metric Threads

Other connections available upon request.

Max Working Pressure

Connection Size	Maximum Working Pressure
1/2"	16 bar
3/4"	16 bar
1"	16 bar
1 1/4"	24 bar
1 1/2"	24 bar
2"	14.5 bar

Safety Relief Valves

Seetru safety valves are compact, highly efficient and incorporate the exclusive Tutchtite® seal technology for repeatable bubble-tight sealing performance. These safety relief valves are designed for applications including air/gas compressors, specialist gas plants, chemical equipment and piping, pressure vessels, thermal relief, medical gases, and more!

Our safety relief valves are manufactured in bronze, brass or stainless steel and offer a wide range of connections, for applications up to 250°C. These valves are manufactured in accordance with a wide range of international standards and approvals such as TÜV (Germany) to AD Merkblatt A2, National Board UV Stamp to ASME Section VIII Division 1, EAC customs union (Russia, Belarus and Kazakhstan), the Canadian CRN and compliant with the requirements of the Pressure Equipment Directive, PED (CE marked).

Valves from Stock: Same-Day-Despatch

Our products are recognised globally for their exceptional quality and reliability, and in recent years Seetru have worked hard to maximise the efficiency of our manufacturing processes, to ensure that we are able to meet demands for supply and distribution. We now hold a large variety of safety valves in stock, allowing customers to purchase certain quantities from our website, and see them despatched on the same day.

Seetru offer atmospheric discharge safety valves and pipped discharge safety valves in brass / bronze or stainless steel. The Seetru LGS® range of pressure relief valves (for liquid, steam, and gasses) are available in bronze construction, with open-lever and sealed-cap options. These valves can be fitted with PTFE or EPDM seals, with both types having the WRAS approval- for installation on public water supply systems.

Seetru also operate a standardised three-day-despatch delivery service, which covers the entire range of valves we manufacture.

Safety Valve Testing Equipment: The Seetru Quicktester™

This compact, lightweight and portable design is very robust and able to meet the demands of a busy maintenance workshop or mobile operation. The Seetru Quicktester™ can be used with plant generated air supplies or with mobile bottled gas. This test-bench can be supplied with a range of adaptors allowing connection between 1/4" to 1" BSP as standard, additional adaptors are available increasing the connection sizes up to 2" BSP. The Quicktester™ is also available with NPT connection adaptors upon request. It is suitable for use with a wide range of elastomer sealed valves