

Type G21 Tubular Marine

The Seetru Marine gauge is designed for use within the marine and offshore industries. Due to its tubular design this gauge is suitable only for use with non-flammable liquids. For flammable liquid applications please see either G35 Seemag or G31 Seeflex.

This gauge is commonly used for the water storage and coolant tanks on board cargo ships, tugs and military vessels.

Example Applications

- Diesel (on land applications)
- Fuel oil (on land applications)
- Water
- Coolants

Specifications

- Maximum working pressure: up to 3.68 bar
- Maximum Operating Temperature: 150°C (depending on O-ring material and sight tube material)
- Maximum Centre Distance: (To suit requirements)
- Minimum Centre Distance – Closed Circuit Design: 150mm (For gauges longer than 1000mm, the column is split into sections using intermediate supports).
- Each section maximum length is 1000mm.

Approvals

- Conforms with EN BS ISO10088 Recreational Craft Directive

Materials of Construction

Component	Material
Valve Units	Brass
	Stainless Steel
Guard Tube	Aluminium
	Stainless Steel
	Brass
	Zinc Plated Mild Steel
Sight Tube	Borosilicate Heat Resisting Glass
	Polycarbonate Plastic
Weld Bosses / Flanges	Zinc Plated Mild Steel
	Stainless Steel



Seal Materials

Seal Material	Temperature Range
Nitrile (NBR)	Up to 120°C
Viton (FKM)	Up to 150°C
EPDM	Up to 150°C
Neoprene	Up to 140°C

Other seal materials available upon request.

Connection Options

Type	Size
Threaded Connections	1/2" BSP or NPT
	3/4" BSP or NPT
Flanged Connections	DIN Flanges
	ANSI Flanges
Weld Boss	42mm OD



Gauge always supplied with a push button self-closing isolation valve at the bottom connection.

Closed Circuit Design

(Connection at top and bottom)

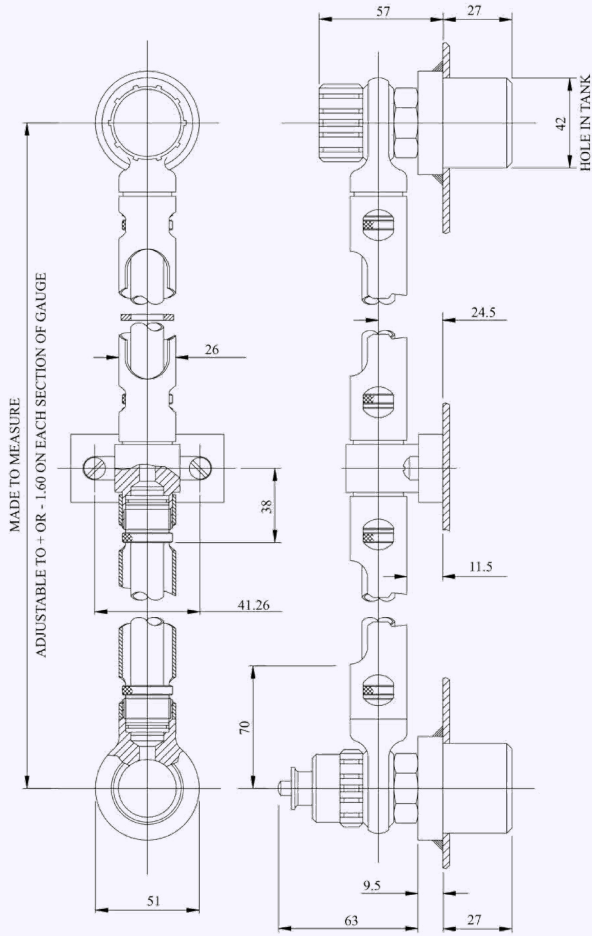

Other Connection Options

THREADED CONNECTION

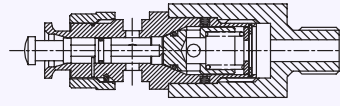

42MM WELD BOSS CONNECTION

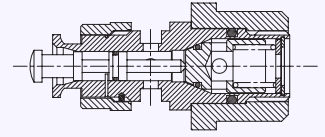

FLANGED CONNECTION

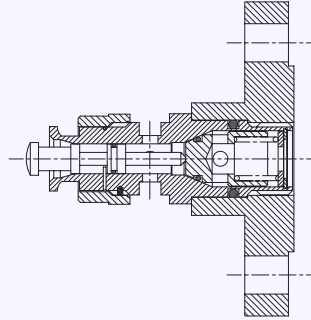

NON-WELD BOSS CONNECTION

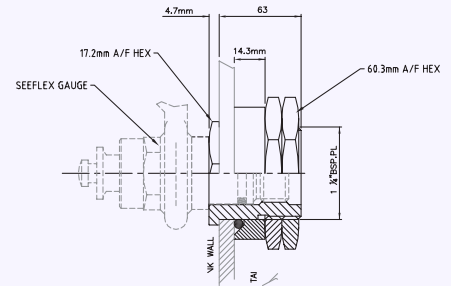

The tank boss is only suitable for use with tanks of wall thickness from 1.58mm (1/16") to 7.9mm (5/16"). hole diameter of 42.0mm is required in the tank wall.

Push-button operation

Except when a reading is being taken, the gauge is permanently isolated from the contents of the tank. To take a reading the spring-loaded valve is opened by pressing a push-button; when released, the connection between the tank and gauge is automatically resealed.

Safe from external damage

Due to the design of the push-button isolation valve, no amount of damage to the gauge or external fittings on the tanks can break the liquid seals. In such an event the fluids cannot escape.

Graduation

Where a measure of the precise storage volume is required, an engraved scale plate can be provided marked with the capacity units.

When ordering please state:

- Distance between gauge centres
- Media identification
- Operating temperature and pressure
- Type of valve units
- Tank connections
- Material of construction