

Type T65



Pressure reducing valve without auxiliary power, Model T65

The task of pressure reducing valves is to control a varying or constant upstream pressure of a medium to a constant outlet pressure (reduced pressure) which is independent of the upstream pressure.

The regulator, model T 65, is suitable for compressible media, such as compressed air, natural gas and for incompressible media such as water and oil, etc.

Pressure reduction occurs by throttling the free cross-section between the seat and the cone. Any change in pressure on the downstream pressure side is immediately converted into a displacement of the valve cone. With zero load, i. e. when the load on the downstream pressure side is zero, the valve does not seal tightly.

With the model T 65 the max. reduction ratio of 10 : 1 should not be exceeded. The lowest downstream pressure is 1 bar.

Mass flow:

A mass flow graph for compressed air at 0°C is given on page 4. A prerequisite is critical flow, i.e. low pressure p_2 (bar_{abs}) / high pressure p_1 (bar_{abs}) = 0.527

With non-critical flow the indicated forward flow must be multiplied with an appropriate multiplier.

$\frac{p_2}{p_1}$ bar _{abs}	0.60	0.70	0.80	0.85	0.90
Multiplier	1	0.933	0.819	0.733	0.617

The velocity of the compressed air in the pipe-work must not exceed 20 m/s.

Examples :

Compressed air : $p_1 = 9 \text{ bar}$; $p_2 = 3 \text{ bar}$

$$\frac{p_2}{p_1} = \frac{4 \text{ bar}_{\text{abs}}}{10 \text{ bar}_{\text{abs}}} = 0.4 \leq \text{critical}, Q = 2700 \frac{\text{m}^3}{\text{h}}$$

Air at 0°C and 1013 mbar

A line gives a regulator *DN 50*

Piping : for 270 m³/h and ~ 20 m/s = *DN 65*

A mass flow graph is given for water at 20°C on page 5. **The velocity of the water in the piping must not exceed 2 m/s.**

Water : $p_1 = 9 \text{ bar}$; $p_2 = 6 \text{ bar}$

$$\Delta p = 3 \text{ bar}_{\text{abs}} ; G = 60 \text{ m}^3/\text{h}$$

A line gives a regulator *DN 65*

Piping : for 60 m³/h and ~ 2 m/s = *DN 100*

For enquiries and orders we would like the following details :

- Upstream pressure
- Downstream pressure (reduced pressure)
- Medium
- Temperature
- Mass flow (forward flow)

Installation notes :

A strainer should normally be installed in the upstream pressure line. Dirt between the seat and cone prevents proper sealing for zero consumption, particularly with compressed air due to the narrow gaps between the seat and cone. It is practicable to install a shut-off valve on the upstream pressure side.

Type T65

Suitable for Gases <
Suitable for Liquids <

IMPORTANT!

It is essential to install a safety valve on the exit side to protect the loads.

With incompressible media the safety valve must be dimensioned such that the flow to the upstream pressure side of the regulator can be passed.

With compressible media the volume given by the flow on the upstream pressure side and the reduction ratio must be able to be passed.

The regulator must be fitted as closely as possible to the loads. Long lengths of piping on the reduced pressure side impair the regulation.

Mounting direction:

The arrow cast on the valve housing must point to the reduced pressure side.

The medium must enter from below the cone. A pulse line does not need to be provided by the customer since this is available on the regulator. However, if required, the pulse line can be routed closer to the loads by the customer.

It has been found practicable to implement the approach and tail distances straight (10 x pipe diameter) so that, where possible, no turbulences, which may affect pressure regulation, occur in front of and behind the regulator.

The regulator can be mounted in any position. With contaminated media fit the regulator horizontally in the piping with the spring hood at the top.

Setting ranges of the downstream pressure and corresponding spring-no.

bar from - to	15-40	50	DN 65	80	100
- 0.40	-	-	29	-	-
0.40 - 0.63	7	29	28	39	38
0.63 - 1.00	9	28	27	38	37
1.00 - 1.60	8	27	26	37	36
1.60 - 2.50	7	26	25	36	35
2.50 - 4.00	6	25	24	35	34
4.00 - 6.30	5	24	23	34	33
6.30 - 10.00	4	23	22	33	32
10.0 - 16.0	3	22	21	32	32+Int.spr.
16.0 - 23.0	-	-	21+Int.spr.	-	-
16.0 - 25.0	2	21	-	32+Int.spr.	-
25.0 - 35.0	-	21+Int.spr.	-	-	-
25.0 - 40.0	1	-	-	-	-

Lower and higher downstream pressures than those specified need special control units.

Versions :

0.7040 / EN-JS1030	DIN PN16
1.0619 / GP240GH	DIN PN40
1.4408 / GX5CrNiMo19-11-2	DIN PN40

- Seat, cone and spindle in stainless steel

2.1050 / CC480K-GS	DIN PN40
--------------------	----------

- Seat, cone and spindle in bronze

With temperatures over 100°C a metal cone seal is used.

For gases other than air multiplication with the following medium factor is used :

Ammonia	= 0.788
Argon	= 1.105
Ethylene	= 1.029
Acetylene	= 0.997
Chlorine	= 1.600
Helium	= 0.351
Carbon dioxide	= 1.265
Carbon monoxide	= 0.983
Coal gas	= 0.640
Air	= 1.000
Methane	= 0.763
Oxygen	= 1.051
Sulphur dioxide	= 1.504
Nitrogen	= 0.983
Hydrogen	= 0.263

For reference quantities other than 0°C and 760 Torr multiply by :

760 Torr	0°C	= 1.000
760 Torr	20°C	= 0.932
1 bar _{abs}	20°C	= 0.902
1 bar _{abs}	0°C	= 0.968

For operating temperatures other than °C multiply by :

$$\text{Factor} = \sqrt{\frac{t+273}{273}}$$

t in [°C]	0 - 10	11 - 50	51 - 100	101 - 150
Factor	1.00	1.10	1.20	1.25
151 - 200	201 - 250	251 - 300	301 - 350	351 - 400
1.32	1.40	1.45	1.50	1.57

Type T65

Suitable for Gases <
Suitable for Liquids <

Model T65

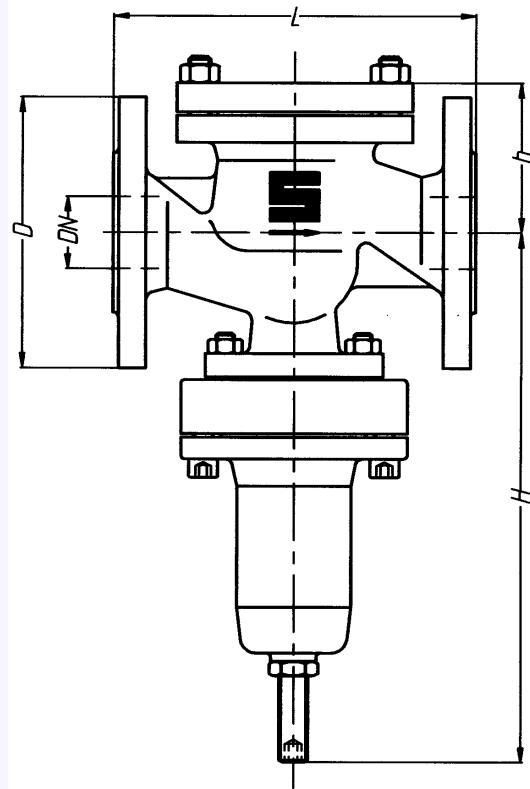

DN	Flanges PN16				Flanges PN40				L	H	h
	D	k	z	i	D	k	z	i			
15	95	65	4	14	95	65	4	14	130	310	90
20	105	75	4	14	105	75	4	14	150	310	90
25	115	85	4	14	115	85	4	14	160	310	90
32	140	100	4	18	140	100	4	18	180	330	120
40	150	110	4	18	150	110	4	18	200	330	120
50	165	125	4	18	165	125	4	18	230	435	130
65	185	145	4	18	185	145	8	18	290	465	155
80	200	160	8	18	200	160	8	18	310	630	180
100	220	180	8	18	235	190	8	23	350	655	180
125	250	210	8	18	270	220	8	26	400	660	210
150	285	240	8	22	300	250	8	26	480	680	235
200	340	295	12	22	375	320	12	29	600	740	285

Dimensions in mm

Installation lengths to EN 558-1

DN	15	20	25	32	40	50	65	80	100
GGG	10,5	10,5	12,0	14,5	15,5	28,5	37,0	56,5	69,0
GS/VA	12,5	12,5	13,5	16,0	18,5	32,5	40,0	66,0	78,0

Weights ~ kg/piece

Type T65

Suitable for Gases <
Suitable for Liquids <

Mass flow graph for T65

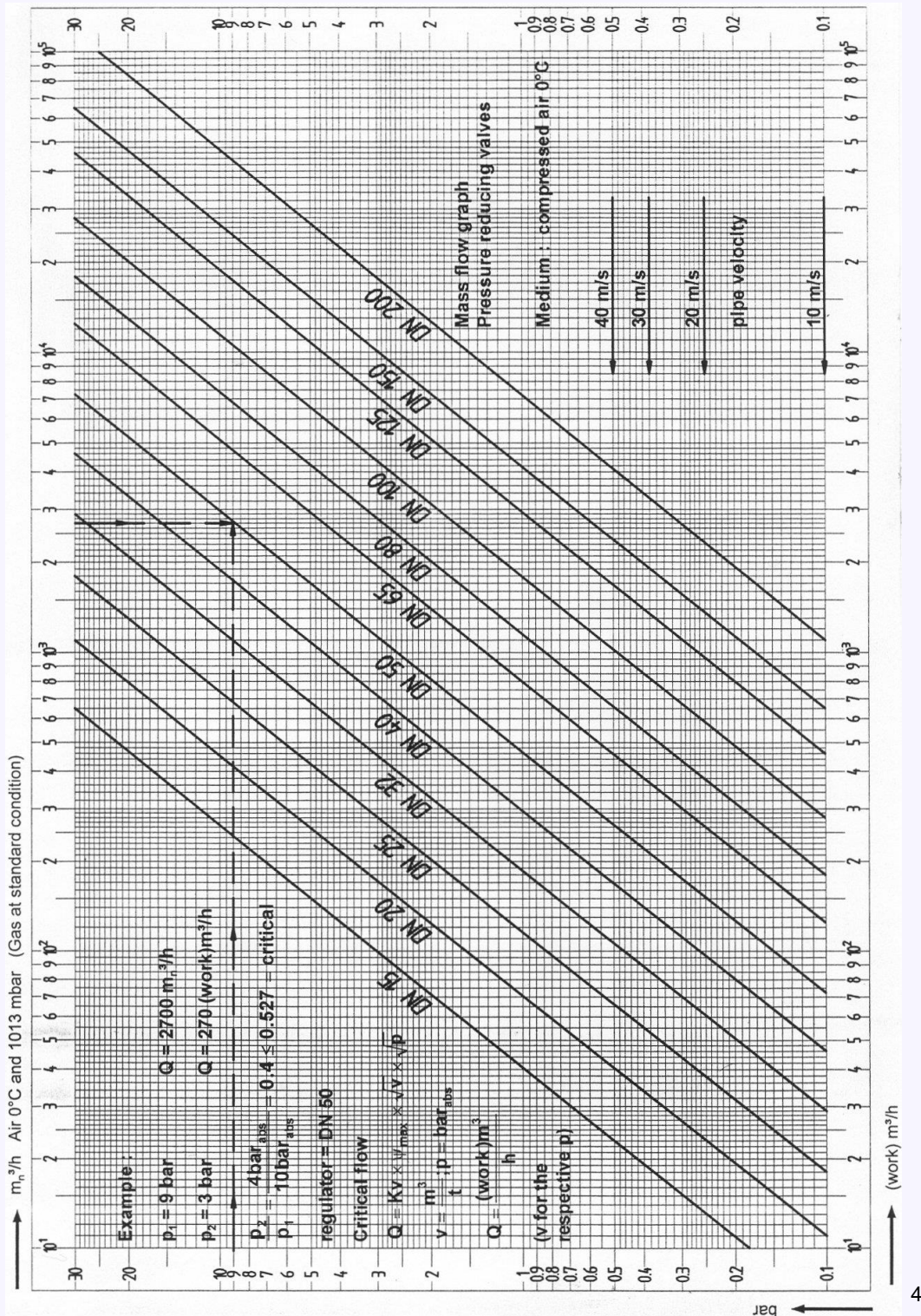

Type T65

Suitable for Gases <
Suitable for Liquids <

Mass flow graph for T65

